

Roller Railside Car Shaker

- EASY INSTALLATION
- UNLOAD CONTINUOUSLY
- REDUCE LABOR COSTS
- EASY REMOTE OPERATION
- CUT UNLOADING TIME BY 75%
- INCREASE TONNAGE PER CAR
- INDUSTRIAL HEAVY DUTY STEEL ROLLERS



Proven to make roll by hopper car loading and unloading more efficient!



The Roller Railside Car Shaker is permanently mounted to the loading or unloading site with a minimum of anchoring requirements. As a car rolls by, the unit extends to contact and shake the car, resulting in superior material movement with out damage to the railcar. One person can easily operate the unit from a distance.

A Roller Railside Car Shaker can:

- ✓ Reduce labor costs
- ✓ Increase productivity
- ✓ Reduce maintenance costs

Air Pressure	100 psi
Air Volume	180 scfm
Weight	3300 lbs
Electrical	120 VAC

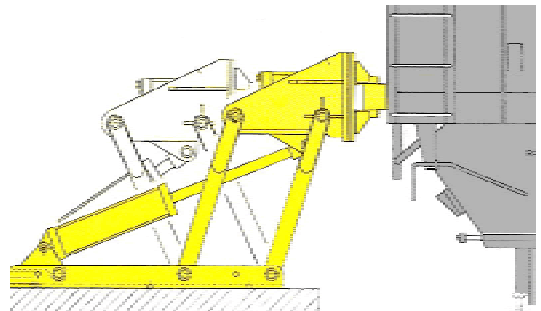

Retraction and Extension showing train contact

Huntsman, Inc. ▼ 2362 Warren Ave. ▼ Twin Falls, Idaho 83301

(877) 733-2214 ▼ (208) 733-2214 ▼ Fax (208) 733-2240

www.huntsmaninc.com ▼ mail@huntsmaninc.com