



Electromechanical Vibrators UV

Operation and Maintenance Instructions

MOUNTING

As a flow aid

When mounting a UV model electric vibrator to the wall of a storage container reinforcement is always used. A channel must be welded to the hopper wall, which extends from the discharge to the intersection of the cone and vertical wall. Skip welding (weld 4", skip 1") the channel will prevent fatigue during normal operation.

A T-slotted mounting plate is a convenient way to attach the vibrator to the channel. The plate must be welded continuously. Do not skip weld the plate.

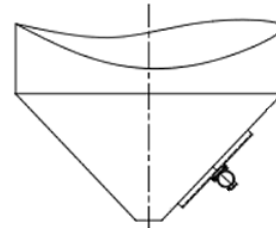

The Electric Vibrator should be mounted at $\frac{1}{4}$ to $\frac{1}{2}$ the distance of the height of the sloped wall. Bolt the vibrator to the slotted mounting plate using the bolts supplied or with commercial grade bolts, lock washers and lock nuts.

As a vibratory equipment drive

Many vibratory equipment applications will require the vibrator be mounted in a vertical position. **NAVCO** Electric Vibrators are designed to be operated in this position. Base and flange mounts are available for special applications. Contact **NAVCO** for details.

NOTE: An electric vibrator must not be operated on a weak mount or lying loose. High amperage occurs under these conditions that can damage the vibrator.

ADJUSTING THE FORCE OUTPUT

Adjustable eccentric weights allow one vibrator to fit a variety of applications. The weight is adjustable in percentage of maximum force output from zero to 100%. Follow the instructions below for adjusting the force output.



Remove cover



Loosen clamp



Set the force output %

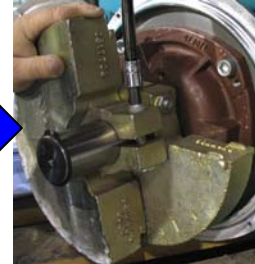

Retighten clamp

1. Disconnect power to motor.
2. Remove both end covers to expose the eccentric weights.
3. Loosen the clamping screws at each end.
4. Rotate the weight around the shaft to the desired mark on the percentage scale to set the max. force output %. The photo shows 80% as an example.
5. Retightened the clamping screws securely.
6. Repeat for other side. Eccentric setting must be the same at both ends.
7. Replace the end covers and tighten.

WARNING: Both pairs of weights (at each end of the drive) must be adjusted to the same setting to avoid transversal vibration that will cause overheating and bearing failure.

Huntsman, Inc. ▼ 2362 Warren Ave. ▼ Twin Falls, Idaho 83301

(877) 733-2214 ▼ (208) 733-2214 ▼ Fax (208) 733-2240
www.huntsmaninc.com ▼ mail@huntsmaninc.com

CONNECTION

The electrical connection should be made according to the connection diagram located under the terminal box cover. Inside the terminal box, the leads must take the shortest route possible from the connector to the terminal. Outside the terminal box the electric cable should be flexible and free of strain. It is important the cable not be tensioned to avoid breakage due to vibration. The connection should be checked for extreme movement with the vibrator in operation. Do not connect any vibrator using rigid conduit.

At start up the amperage may be as high as eight (8) times the nameplate amperage. This high amperage draw will drop to the amperage specified on the nameplate as the vibrator reaches operating speed. Maintained high amperage will cause overheating and vibrator failure.

We recommend an amperage check at startup to avoid damage to the vibrator motor. If amperages read high, check all mounting fasteners and tighten where required. A weak mount or oversized vibrator can create enough movement to cause high amperage and damage the vibrator and the hopper or equipment.

Lightweight container walls must be sufficiently reinforced to provide a rigid mount. As a rule of thumb, if the nameplate is not readable when the vibrator is operating then the vibrator is not mounted rigidly enough.

A motor protective device or switch is recommended for all NAVCO Electric Vibrators. The starting current can be as high as eight (8) times the full load nameplate amperage. Overload protection must be sized accordingly.

With the connection complete, attach an ammeter and start the vibrator. The high amperage at start up should fall to within 10% of the nameplate rating. If amperage reads in excess of 10% high, check and tighten mounting fasteners and mounting plate welds. Any loose mounting must be corrected to reduce high amp draw. If an ammeter is not available, examine the mount and Mount Plate welds.

WARNING: The greatest reason for all damage and disruption is caused by insufficient attachment of the drive!

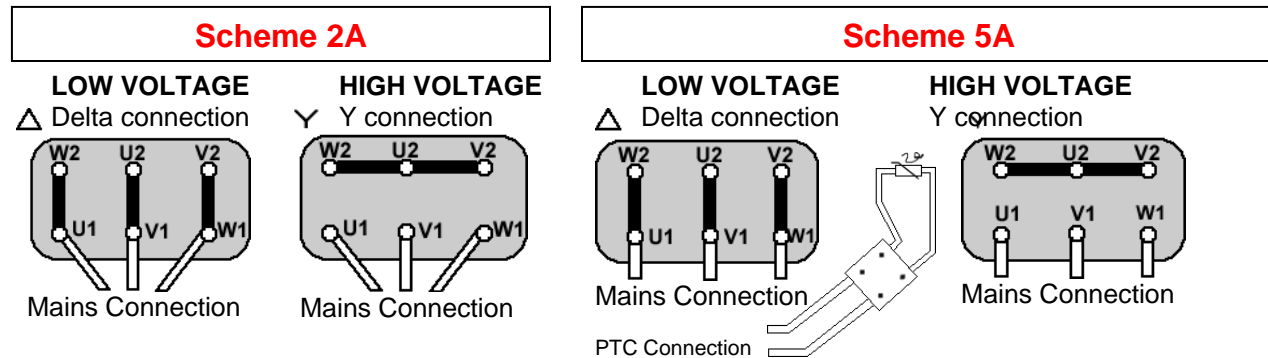

MAINTENANCE

NAVCO Electric Vibrators are designed for continuous duty so the motors are permanently lubricated and most models do not require relubrication. However some larger models do require topping-off the lubricant. If a lubricating nipple is visible on the outer housing, see the vibrator model's technical specifications bulletin for a lubrication schedule. To assure maximum vibrator life the lubrication schedule should be closely maintained.

A preventative maintenance program should also include an inspection of the mount and fasteners for tightness. Routinely check the Mount Plate welds and the hopper wall for signs of fatigue. Early detection can prevent costly repairs. In continuous duty applications, a container is often allowed to run empty. This should be avoided. Vibration on an empty container could cause weld or metal fatigue.