

Vibrators for Power Plants

Flow Aid Solutions for coal handling and more

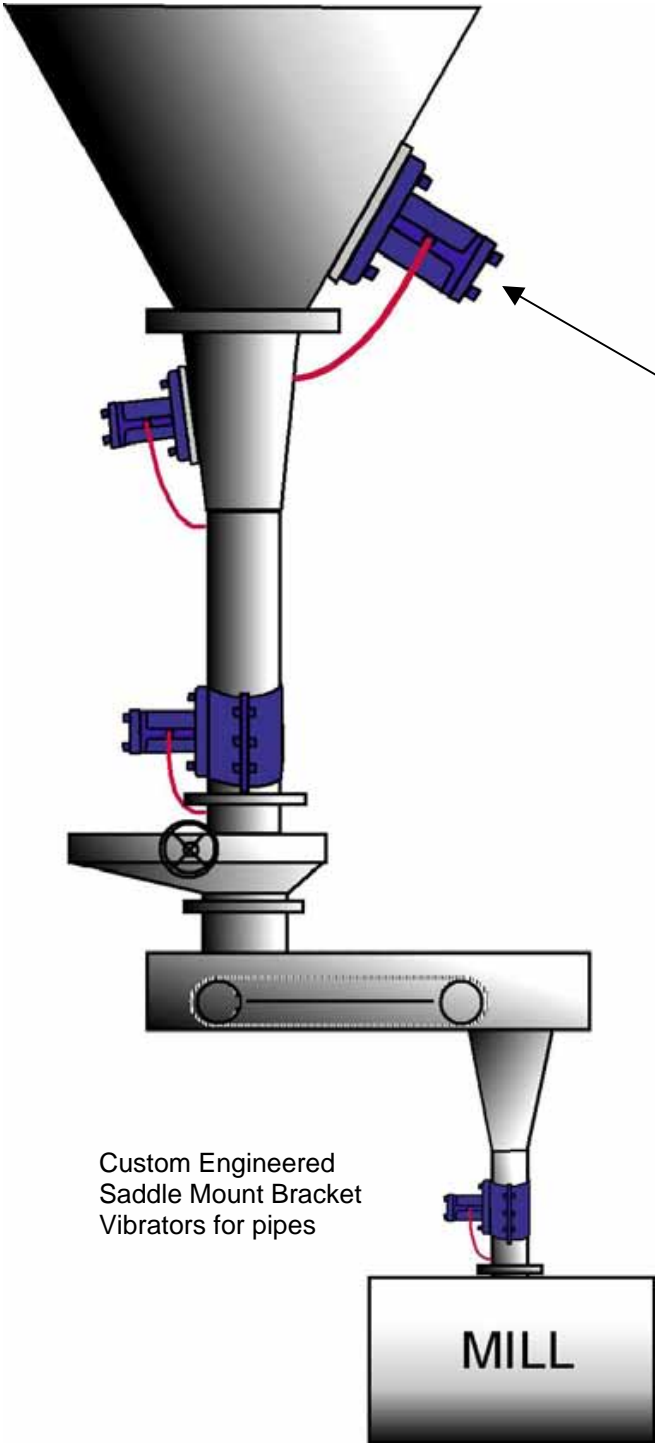

A Big BH 8
Weight: 650 lbs.



The most powerful vibrator available for stubborn coal in large bunkers.



HOUSTON, TX

The NAVCO Big BH, a high amplitude, low frequency, pneumatic piston vibrator, is the best flow aid device available for facilitating coal flow through chutes and bunkers. BHs are designed for heavy duty, harsh condition service on large capacity, thick plate storage bunkers. NAVCO models are available in several sizes that work well on bunkers, chutes, bins and hoppers through out the coal fired power plant.

BH vibrators generate linear vibration, have a large area of influence, reduce material sliding friction and promote fast and complete movement of material. Unlike blasters, the BH has a larger area of influence that makes it effective for dislodging even the most stubborn compacted pockets of sticky coal.

NAVCO Vibrators eliminate the need for manual clean out of bunkers, greatly reducing costly shut downs, labor requirements, and hazardous conditions.

Electric alternatives:



Above: NAVCO offers electromechanical vibrators that work well in a variety of power plant applications.

BH Pipe Mount



BH Pneumatic Piston Vibrators have many uses at coal-fired power plants

Benefits:

- Keeps wet, sticky coal moving.
- Designed for use in harsh conditions.
- Pipe/Chute mount system available.
- Eliminates need for sledgehammering.
- Easy installation does not require penetration of bunker walls.
- Reduces the risk of spontaneous combustion from compacted coal.
- Eliminates the need for manual clean out.

Applications:

BH vibrators are ideal coal **chutes** and **bunker** applications, they also have other uses in the plant including:

- **Baghouses** perform optimally when a BH helps remove fly ash.
- **Railcars Dump Hoppers** empty more reliably when BH vibrators are installed on the walls.
- **Lime and Scrubber Sludge** –BH vibrators help facilitate flow from railcars, trucks and hoppers.
- **Hydrobins** - Stubborn bottom ash is easily removed by a big BH.
- **ESPs** – Electrostatic Precipitator Electrodes are cleaned effectively by BH vibrators.

*NAVCO offers special mountings designed to carry heat away from the vibrator for less wear and a longer life.

Huntsman, Inc. ▼ 2362 Warren Ave. ▼ Twin Falls, Idaho 83301

(877) 733-2214 ▼ (208) 733-2214 ▼ Fax (208) 733-2240
www.huntsmaninc.com ▼ mail@huntsmaninc.com