



Leaders in Separation Technology

Industrial Fans

Forsberg, Inc., one of the nation's leaders in the manufacturing of dry granular separation machinery, has long recognized the importance of air systems as it applies to their own line of vacuum machinery. Forsbergs has been manufacturing their own industrial fan line for over 60 years in order to meet the performance requirements not found in "standard" industrial fans.

These fans are available in either clockwise or counterclockwise rotation.

Contact Forsberg for your free product evaluation in our testing facility to ensure complete customer satisfaction prior to your purchase.

Large or Small...A Forsberg Fan Will Meet The Challenge!

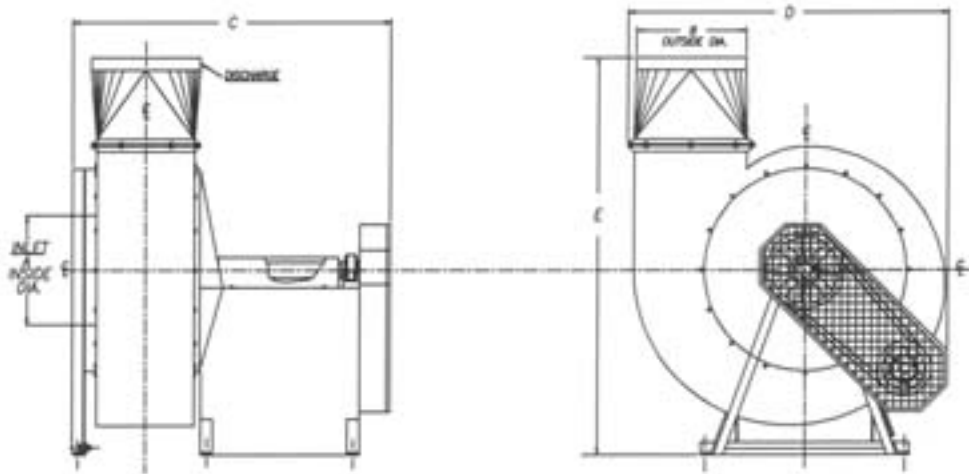

Specifications

MODEL	WHEEL DIAMETER	INLET (A)	OUTLET (B)	OVERALL DIMENSIONS		
				(C)	(D)	(E)
8-HA	14	8	8	27	28-3/4	37-1/2
12-HA	19-1/8	12	12	37	34	45
14-HA	22-5/8	14	14	40-7/8	41	50-1/4
16-HA	29-5/8	16	16	46-1/4	48	60-1/8
18-HA	33	18	18	50	54	65-3/8
19-HA	33	19	19	50	54	65-3/8
21-HA	36-1/2	21	21	64-15/16	74-1/2	82-1/4
23-HA	40	23	23	67-3/4	76-1/2	85

Above dimensions are in inches.

Forsberg Blower Positioning Chart Outlet can be positioned every 22-1/2 degrees on 12-HA, 14-HA, 16-HA, 18-HA and 19-HA; every 15 degrees on 21-HA, and 23-HA; and every 45 degrees on 8-HA.

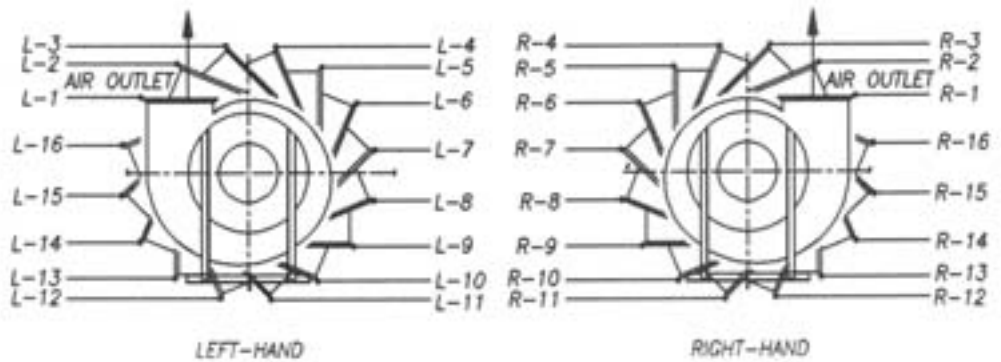

Huntsman, Inc.
 2362 Warren Ave. Twin Falls, Idaho 83301
 (877) 733-2214 (208) 733-2214 Fax (208) 733-2240
 www.huntsmaninc.com mail@huntsmaninc.com