

BC Scale



BC 25 Scale



BC 50 Scale

The Gustafson BC Scale (BC 25 & BC 50) is designed to weigh any free-flowing material up to 50tons per hour. Gustafson's patent-pending flow-through weighing scale can handle a variety of products in many applications. The highly versatile design allows integration with an electronic monitoring system.

OPERATION...

Product flows from the hopper through the control gate and into a series of baffles, which directs the product flow through the scale. This unique design achieves a longer "dwell time" for a more accurate weight, better than +/- 2%.

FEATURES & BENEFITS...

- Compact and versatile design for most free-flowing dry product applications
- Evacuation ports for dust removal
- Inspection door with clean-out grate stops over-sized foreign matter from entering the scale
- Flow regulating inlet gate helps to even surges from product flow, for accuracy and overload protection
- Stainless steel construction for longer machine life
- Flow rate and total indicator plus 4-20ma output in NEMA 4X enclosure (32-100dg F optimum operating)
- Equipped with 25' of cable

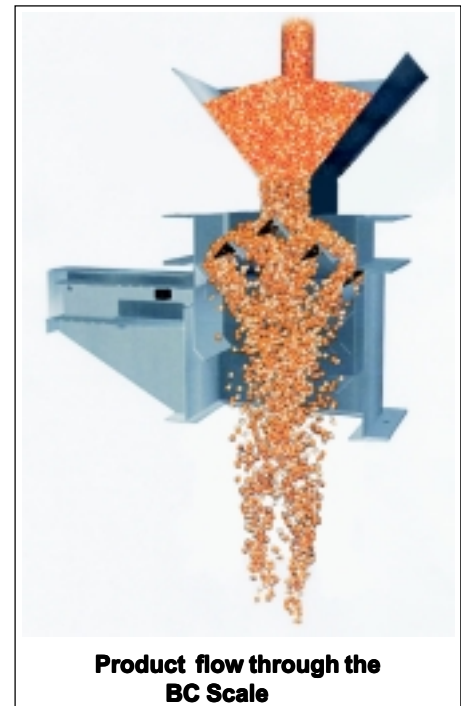

Product flow through the BC Scale

Technical Data

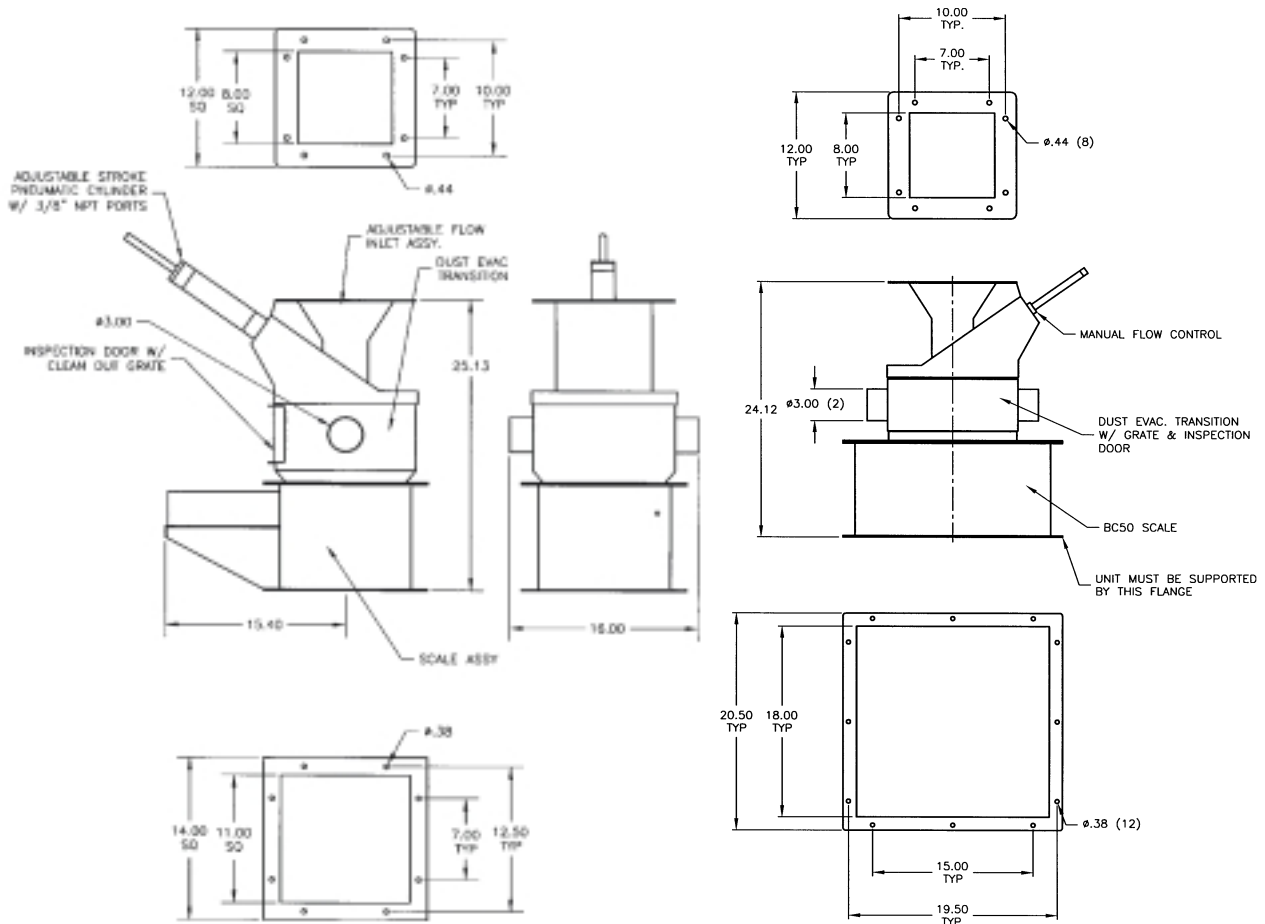

BC-25 Auto Scale Assembly

(Pneumatic adjustable stroke flow control for both the BC-25 & 50 scales is standard when ordered with the GLCPS).

BC-50 Manual Scale Assembly

(Manual flow control for both the BC-25 & 50 scales is standard when ordered as a scale only).

www.gustafgustaf.com
ISO 9001 REGISTERED

HUNTSMAN, INC.
 2362 Warren Ave.
 Twin Falls, ID 83301
 (888)812-3377
 Fax:(208)733-2240

02/27/2002
 TT-BC Scale-A
 Printed in the U.S.A.