



*"Setting The Standard For Supplier Excellence"*

## **TrueCap<sup>®</sup> RF Capacitance Point Level Sensors**

- ▼ Extensive Product Line for Bulk Solid Applications
- ▼ Superior Sensitivity of 0.5pF is Standard
- ▼ Maximum Reliability and Calibration Stability
- ▼ Automatic Material Build-Up Immunity
- ▼ Universal Power Supply Available
- ▼ Twist On/Off Cover
- ▼ Two-year Warranty
- ▼ Liquid and Slurry Applications





## TrueCap<sup>®</sup> RF Capacitance Point Level Sensors

TrueCap<sup>®</sup> RF capacitance sensors offer cost-effective point level monitoring with reliability you can count on. Monitor's complete line, which features models MK-2 and MK-2e, provides you with the most affordable solution for your application. Monitor's RF capacitance probes are designed to provide a high level of sensitivity, stability and durability for powder and bulk solids applications, as well as liquid and slurry applications. Monitor's two-year warranty stands behind every TrueCap sensor.



This Model MK-2e is monitoring the level of latex paint.

### PRINCIPLE OF OPERATION

A radio frequency is applied to the probe and is continually analyzed to determine the influence caused by the surrounding environment. As material contacts the probe,

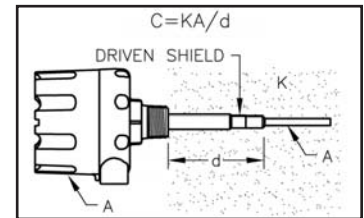

the radio frequency shifts indicating an increase in capacitance (C). The active probe of the unit and the vessel's wall make up the two plates (A=area) of a capacitor which are separated by a fixed distance (d). The probe's insulator and surrounding air provide the dielectric material (with dielectric constant "K"). As the air (K=1.0) is displaced with any other material (K > 1.0), the capacitance effect (C) is enhanced, thereby changing the application's impedance. This influence is measured within the circuitry and compared to a reference established by the sensitivity setting. The setting determines how much influence must be present before the output changes.

The driven shield section of the probe enables the circuitry to ignore product build-up on the probe that would otherwise cause false sensing. The driven shield is activated with the same radio frequency potential as the sensing probe. Since current can not flow between identical potentials, the driven shield blocks current flow from the active probe to the vessel wall through the material build-up, thereby eliminating the sensing of the material build-up.

### APPLICATIONS

TrueCap<sup>®</sup> RF capacitance point level sensors are versatile devices providing high and low level readings in bins, silos, tanks, hoppers, and other vessels.

TrueCap's superior sensitivity range allows users to properly adjust units to meet the needs of a wide variety of applications. Whether your application is for a powder, liquid, granular solid, or viscous material, the TrueCap product line offers the right solution.





TYPICAL APPLICATIONS INCLUDE, BUT ARE NOT LIMITED TO:

- ▼ Chemicals
- ▼ Pellets
- ▼ Rubber
- ▼ Liquids
- ▼ Wastewater
- ▼ Cement
- ▼ Powders
- ▼ Paint & Coatings
- ▼ Paper Pulp
- ▼ Plastics
- ▼ Feed/Grain
- ▼ Granular Solids
- ▼ Sand
- ▼ Slurries
- ▼ Pharmaceuticals
- ▼ Coal
- ▼ Oils
- ▼ Food Ingredients

### MODEL SELECTION

Monitor offers the market an unmatched selection of RF Capacitance point level sensors. Several parameters should be considered when selecting the proper **TrueCap**® RF capacitance point level sensor.

#### EASE OF CALIBRATION

Many applications are well served by the manual calibration of the MK-2e, but only the MK-2 offers the extraordinary convenience of push-button calibration, sensitivity and self-test.

#### CALIBRATION LOCATION

Some applications place probes in locations which are difficult to access. The Remote Calibration Module (MK-2 only) provides all push-button functions from a location up to 1,000 feet (305 m) away from the probe. Also, the split architecture versions of both the MK-2 and MK-2e provide remote calibration 12 feet (3.7 m) or more away from the probe.

#### VARYING TEMPERATURES

It is important that the calibration of a probe remains stable during swings in the process and ambient temperatures. The MK-2 automatically adjusts its calibration to account for temperature changes providing maximum reliability.

#### CHANGING CONTENTS/CHARACTERISTICS

**TrueCap** sensors can be calibrated to the material with the lowest dielectric constant (usually the driest material) in order to sense all products which could enter the bin. However, sometimes the need for re-calibration is unavoidable, making the MK-2 with push-button calibration and an available remote calibration module the best choice.

<i>MK-2</i>	<i>MK-2e</i>
Provides the highest performance and reliability over the widest range of applications	Designed to provide high performance and reliability with a lower cost
Wide assortment of probe types and options for versatility	Wide assortment of probe types and options for versatility
Suitable for dry solids, wet solids, liquids, viscous liquids, and slurries	Suitable for dry solids, wet solids, liquids, viscous liquids, and slurries
Hazardous Locations Approval Available	Hazardous Locations Approval Available
Internal bin temperatures up to 450°F (232°C) (Split-Architecture)	Internal bin temperatures up to 450°F (232°C) (Split-Architecture)
Split-Architecture to remote mount electronics	Split-Architecture to remote mount electronics
Immunity to product build-up on probe	Immunity to product build-up on probe
Unaffected by high vibration (Split-Architecture)	Unaffected by high vibration (Split-Architecture)
Tolerant of wide temperature fluctuations without recalibration	
Quick/Simple recalibration (push-button) to handle varying materials	
Universal Power Supply	
Remote calibration option (up to 1000ft (305m) from electronics)	



### HEAVY MATERIALS & TIGHT AREAS

Some applications require compact, sturdy probes for heavy materials or confined spaces. The MK-2 and MK-2e offer a stub probe for extra durability for heavy products and a compact design for tight areas. Both models also use heavy duty 3/8 inch (9.5 mm) diameter probes.

### SOLIDS

All **TrueCap** sensors can sense solid materials, but be careful to also look at all application parameters.

### MATERIAL COATING/BUILD-UP

Many liquids, slurries and sticky bulk solids tend to cling to probes. Product build-up immunity through a driven shield design is a must. The MK-2 and MK-2e provide product build-up immunity and can typically be used with these materials.

### HIGH VIBRATION

When locating sensors near vibrators, bin dischargers or other vibrating equipment, the split architecture version is recommended.

### UNIVERSAL POWER SUPPLY

Minimizing the number of variations can maximize value for OEMs and product resellers. The MK-2 is the only **TrueCap** sensor that provides this capability.

### NEED FOR VISUAL INDICATION

Both the MK-2 and the MK-2e are provided with a high intensity LED indicator on the housing (Ordinary location integral sensors only).

### HAZARDOUS LOCATIONS

The MK-2 and MK-2e are available approved for Class I and Class II hazardous locations. See "Specifications" for details.

### HIGH TEMPERATURE

For applications up to 450°F, (232°C) the MK-2 and MK-2e offer stainless steel mounting connections which act as thermal barriers and a split architecture version which completely removes the electronics from the process.

### LARGE PARTICLES

Large particles can leave air gaps which could lead to inaccurate readings. However, smaller particles and fines usually fill in the gaps.

APPLICATION/PARAMETER	MK-2	MK-2e
Ease of Calibration	Best	Fair
Calibration Location	Best	Good
Varying Temperatures	Best	Good
Changing Contents/Characteristics	Best	Good
Heavy Materials & Tight Areas	Good	Good
Solids	Best	Good
Material Coating/Build-Up	Best	Good
High Vibration	Best	Best
Need for Visual Indication	Best	Best
Hazardous Locations	Best	Best
High Temperature	Good	Good
Large Particles	Good	Good

### MODEL MK-2

The **TrueCap**® Model MK-2 RF capacitance point level sensor is a proven problem solver used to ensure maximum performance and reliability, minimizing downtime of operations.

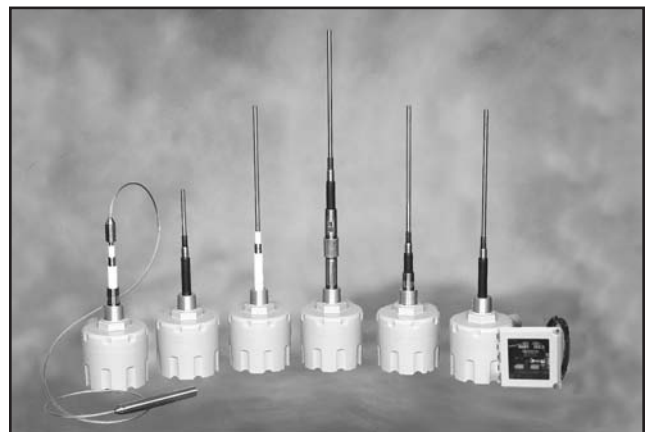

## MODEL MK-2 FEATURES

- ▼ Microcontroller based for maximum reliability & performance
- ▼ Push-button calibration, sensitivity selection & self-test
- ▼ Automatic temperature compensation for unmatched calibration stability
- ▼ Superior 0.5pF sensitivity ensures reliability
- ▼ Build-up immunity helps eliminate false signals
- ▼ High intensity LED indicating light (Ordinary location sensors only)
- ▼ Universal power supply minimizes versions
- ▼ Available hazardous locations approval with intrinsic safety



## SPLIT ARCHITECTURE

For applications involving high temperature or vibration, the probe and electronics are housed in separate enclosures mounted 12 feet (3.6 m) apart or more depending on the application, thereby removing the electronics from the stressful conditions. All adjustments are performed at the remote electronics.



## MODEL MK-2 ACCESSORIES

### REMOTE CALIBRATION MODULE

Monitor offers a Remote Calibration Module (RCM) designed to interface with the standard MK-2. This panel mount module can be installed near other control equipment, up to 1,000 feet (305 m) from the sensor. An optional wall mount enclosure is available.

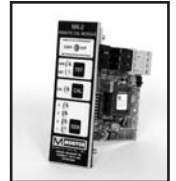

### MOUNTING PLATES

Painted carbon steel or stainless steel mounting plates eliminate the need to weld a mounting coupling to the vessel.

### PROBE EXTENSIONS

Rigid probe extensions with solid or flexible couplings easily extend the sensing point to a desired distance from any top-mounted **TrueCap**® probe.

## MODEL MK-2 OPTIONS

### FOOD GRADE PROBE

Most probe variations are available with nylon insulators for food grade applications. Food grade probes are usually outfitted with the stainless steel connection.



### HAZARDOUS APPROVALS

Most MK-2 models are offered with explosion proof housings and intrinsically safe probes thereby meeting requirements for Class I and Class II environments. See "Specifications" for details.

### SS CONNECTION

A 3/4" NPT 316 stainless steel mounting connection for applications requiring material compatibility enhances the effectiveness in food grade or corrosive applications.



## MODEL MK-2e

The **TrueCap**® Model MK-2e RF capacitance point level sensor is a reliable sensor and is a standard for many OEMs and end users requiring versatility and lower cost.



## MODEL MK-2e FEATURES

- ▼ Superior 0.5pF sensitivity ensures reliability
- ▼ Build-up immunity helps eliminate false signals
- ▼ High intensity LED indicating light (Ordinary location integral sensors only)
- ▼ Available hazardous locations approval with intrinsic safety
- ▼ Simple 2-step manual calibration
- ▼ Economical



## MODEL MK-2e OPTIONS

### FOOD GRADE PROBE

Most probe variations are available with nylon insulators for food grade applications. Food grade probes are usually outfitted with the stainless steel connection.



### HAZARDOUS APPROVALS

Most MK-2e models are offered with explosion proof housings and intrinsically safe probes thereby meeting requirements for Class I and Class II environments. See "Specifications" for details.

### SS CONNECTION

A 3/4" NPT 316 stainless steel mounting connection for applications requiring material compatibility enhances the effectiveness in food grade or corrosive applications.



### SPLIT ARCHITECTURE

For applications involving high temperature or vibration, the probe and electronics are housed in separate enclosures mounted 12 feet (3.6 m) apart or more depending on the application, therefore removing the electronics from the stressful conditions. All adjustments are performed at the remote electronics.



## MODEL MK-2e ACCESSORIES

### MOUNTING PLATES

Painted carbon steel or stainless steel mounting plates eliminate the need to weld a mounting coupling to the vessel.

### PROBE EXTENSIONS

Rigid probe extensions with solid or flexible couplings easily extend the sensing point to a desired distance from any top-mounted **TrueCap**® probe.

## MODEL MK-2 & MK-2e PROBE VARIATIONS

DIMENSIONS ARE SHOWN IN INCHES WITH MILLIMETER EQUIVALENT IN BRACKETS

### STANDARD PROBE

The most commonly used probe variation, the standard probe performs reliably in many different applications. The standard probe is available with either a 1-1/4" NPT, 1-1/2" BSPT\* or 3/4" NPT process connection.



\*Unit with 1-1/2" BSPT connection is provided with M20 cable glands.

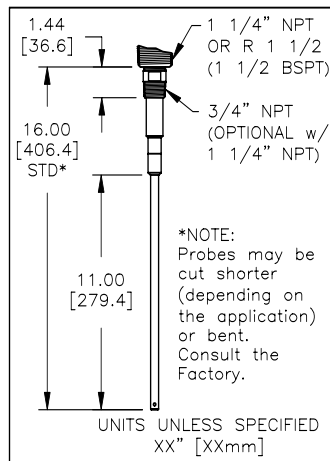

### STUB PROBE

Usually used in tight spaces, or in applications with heavy material, the stub probe is a shorter version of the standard probe. The stub probe is available with either a 1-1/4" NPT, 1-1/2" BSPT\* or 3/4" NPT process connection.

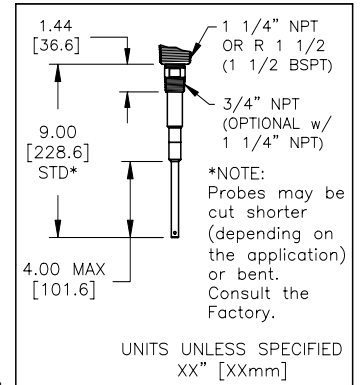

\*Unit with 1-1/2" BSPT connection is provided with M20 cable glands.

### CABLE EXTENSION PROBE

The cable extension probe can extend the sensing point up to 50 feet (15 m) beneath the mounting point. It should be noted that the build-up immunity, however, is not extended with the cable version. Use the pipe extension probe in those applications requiring build-up immunity. A 1-1/4" NPT, 1-1/2" BSPT\* or 3/4" NPT process connection is available.

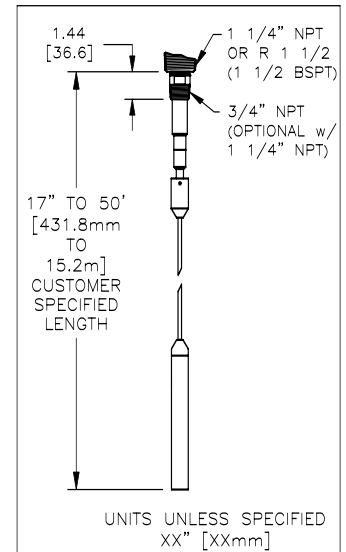

\*Unit with 1-1/2" BSPT connection is provided with M20 cable glands.

### PIPE EXTENSION/LAGGED HOUSING

The pipe extension probe extends the sensing point and build-up immunity up to 12 feet (3.6 m) down into the bin. The lagged housing version "Lags" the housing up to 24 inches (610 mm) away from the mounting point for high temperature applications and/or vessels with external insulation.

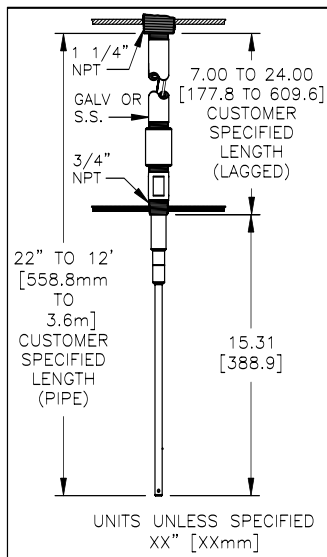

### MODEL MK-2 & MK-2e MECHANICALS

DIMENSIONS ARE SHOWN IN INCHES WITH MILLIMETER EQUIVALENT IN BRACKETS

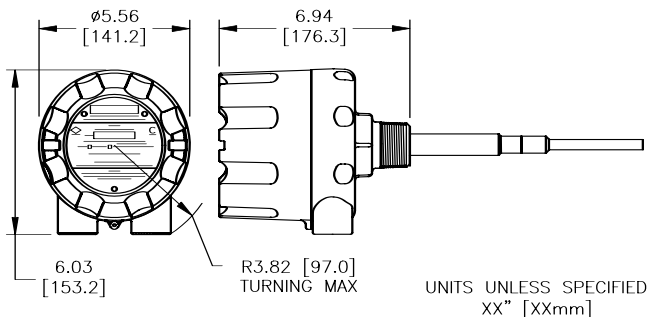

### MODEL MK-2 ORDERING INFORMATION

#### RF CAPACITANCE INTEGRAL SENSORS



**ELECTRONICS TYPE**  
1 = Standard<sup>1&2</sup>

**PROBE TYPE**  
1 = Standard - Ryton®  
2 = Food Grade - Nylon  
3 = Stub - Ryton  
4 = Stub - Nylon  
6 = Cable Ext - Nylon

**APPROVALS**  
1 = Hazardous<sup>2&6</sup>  
2 = Ordinary

**OPERATING VOLTAGE**  
1 = Universal  
48-240 VAC  
24-48 VDC

**PROBE CONNECTION**  
1 = 1-1/4" NPT Alum.  
2 = 1-1/4" & 3/4" SS<sup>3,4&6</sup>  
3 = Pipe ext/Galv<sup>3,4&6</sup>  
4 = Pipe ext/SS<sup>3&4</sup>  
5 = Lagged/Galv<sup>5&6</sup>  
6 = Lagged/SS<sup>5</sup>  
7 = 1-1/2" BSPT Alum<sup>7</sup>

#### SPLIT ARCHITECTURE REMOTE ELECTRONICS<sup>8</sup>



**ELECTRONICS TYPE**  
1 = Standard<sup>1&2</sup>

**APPROVALS**  
1 = Hazardous<sup>2&9</sup>  
2 = Ordinary

**OPERATING VOLTAGE**  
1 = Universal  
48-240 VAC  
24-48 VDC

#### REMOTE PROBES<sup>8</sup>



**PROBE TYPE**  
1 = Standard - Ryton®  
2 = Food Grade - Nylon  
3 = Stub - Ryton®  
4 = Stub - Nylon  
6 = Cable Ext - Nylon

**APPROVALS**  
1 = Hazardous<sup>6&9</sup>  
2 = Ordinary

**PROBE CONNECTION**  
1 = 1-1/4" NPT Alum.  
2 = 1-1/4" & 3/4" SS<sup>3,4&6</sup>  
3 = Pipe ext/Galv<sup>3,4&6</sup>  
4 = Pipe ext/SS<sup>3&4</sup>  
7 = 1-1/2" BSPT Alum<sup>7</sup>

#### Cable Assembly

11-1015 Cable Assembly, 12ft. 22awg Co-ax/18awg Wire  
Consult factory for longer lengths



**CONSULT FACTORY FOR AVAILABLE CONFIGURATIONS.  
NOT ALL COMBINATIONS ARE OFFERED.**

- 1 Features push-button calibration, sensitivity & test functions, and remote calibration capability.
- 2 External indicators on ordinary location units only.
- 3 Overall insertion length for pipe extension to be specified by customer. From 22" (559 mm) up to 12 ft (3.6 m) maximum.
- 4 For pipe extension probes with overall length exceeding 6-1/2ft (2m), the unit must be shipped by truck
- 5 Lagged length to be specified as 7 to 24 inches (178 to 610 mm).
- 6 Hazardous locations approval on units with Pipe Extension or Lagged Probes are available on the SS version ONLY. Hazardous locations approval is not available on the galvanized version. Consult specifications for all Hazardous locations approval ratings. Hazardous location units are **NOT** CE approved.
- 7 1-1/2" BSPT process connection is available with only the Standard, Food Grade, Stub and Cable Extension probes. Not available with 3/4" SS Combo, Pipe Extension or Lagged units.
- 8 Electronics assembly must be purchased with Remote Probe and 11-1015 Cable Assembly.
- 9 Remote Electronics with hazardous locations approval must be ordered with a Remote Probe with hazardous locations approval. Hazardous location units are **NOT** CE approved.

**REMOTE PROBES<sup>8</sup>**

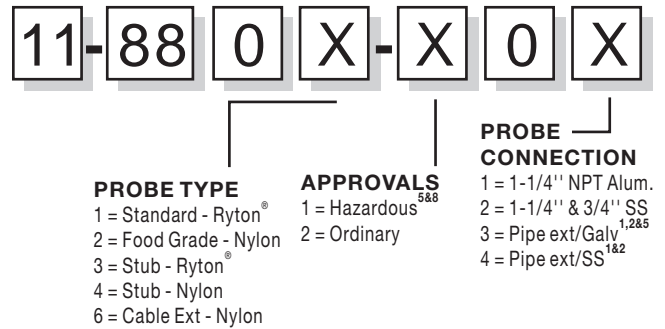

**Cable Assembly**

- 11-1015 Cable Assembly, 12ft. 22awg Co-ax/18awg Wire  
 Consult factory for longer lengths

**CONSULT FACTORY FOR AVAILABLE CONFIGURATIONS.  
NOT ALL COMBINATIONS ARE OFFERED.**

- 1 Overall insertion length for pipe extension to be specified by customer. From 22" (559 mm) up to 12 ft (3.6 m) max.
- 2 For pipe extension probes with overall length exceeding 6-1/2ft (2m), the unit must be shipped by truck.
- 3 Lagged length to be specified as 7 to 24 inches (178 to 610 mm).
- 4 24VDC operating voltage selection is not available with hazardous locations unit.
- 5 Hazardous locations approval on units with Pipe Extension or Lagged Probes are available on the SS version ONLY. Hazardous locations approval is not available on the galvanized version. Consult specifications for all Hazardous locations approval ratings.
- 6 1-1/2" BSPT process connection is available with only the Standard, Food Grade, Stub and Cable Extension probes. Not available with 3/4" SS Combo, Pipe Extension or Lagged units.
- 7 Electronics assembly must be purchased with Remote Probe and 11-1015 Cable Assembly.
- 8 Remote Electronics not available with hazardous locations approval. Use Model MK-2.

**MODEL MK-2e ORDERING INFORMATION**

**RF CAPACITANCE INTEGRAL SENSORS**

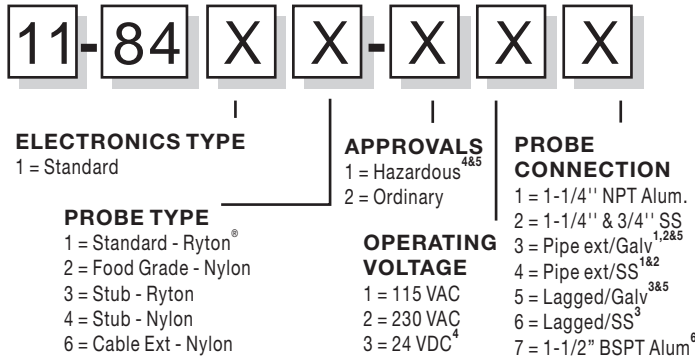

**SPLIT ARCHITECTURE REMOTE ELECTRONICS<sup>7</sup>**

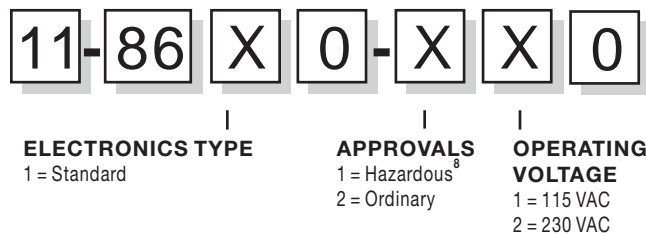

## PROBE SPECIFICATIONS

### Standard/Food Grade Probe

Mounting:	1-1/4" NPT alum, R 1-1/2 (BSPT 1-1/2), or combo 3/4" NPT 316SS and 1-1/4" NPT alum
Probe Material:	3/8in(9.5mm) dia. 316SS probe & guard, Ryton® & Nylon insulators
Probe Length:	16in(406mm) from alum mounting
Temp (Probe Only):	Ryton® +450° F (+232° C) max; Nylon +300° F (+148° C) max
Pressure:	50 psi(3.5 bar) max (alum connection); 150 psi(10 bar) max (3/4" NPT SS)

### Stub Probe

Mounting:	1-1/4" NPT alum, R 1-1/2 (BSPT 1-1/2), or combo 3/4" NPT 316SS and 1-1/4" NPT alum
Probe Material:	3/8in(9.5mm) dia. 316SS probe & guard, Ryton® & Nylon insulators
Probe Length:	9" (229mm) from aluminum mounting
Temp (Probe Only):	Ryton® +450° F (+232° C) max; Nylon +300° F (+148° C) max
Pressure:	50 psi(3.5 bar) max (alum connection); 150 psi(10 bar) max (3/4 NPT SS)

### Cable Extension Probe

Mounting:	1-1/4" NPT alum, R 1-1/2 (BSPT 1-1/2), or combo 3/4" NPT 316SS and 1-1/4" NPT alum
Probe Material:	1/8in(3.2mm) diameter 316 SS Teflon® jkt'd cable, Nylon insulator
Cable Length:	Customer specified from 17" (432 mm) up to 50 ft (15 m) overall insertion from aluminum mounting
Temp (Probe Only):	+300° F (+148° C) max
Pressure:	50 psi(3.5 bar) max (1-1/4 NPT alum); 150 psi(10 bar) max (3/4 NPT SS)

### Pipe Extension Probe

Mounting:	1-1/4" NPT alum
Lag Material:	Galvanized or 316SS
Pipe Ext Length:	Customer specified from 22" (559 mm) up to 144in (3.6m) overall insertion
Interface To:	Standard or Food Grade (See applicable specs)

### Lagged Housing Version

Mounting:	3/4" NPT 316SS
Lag Material:	Galvanized or 316SS
Lag Length:	Customer specified from 7 to 24 in (178 to 610 mm)
Interface To:	Standard Probe only (See applicable specs)

### Split Architecture

Elec. Enclosure:	Cast Aluminum, screw-on cover, polyester powder coat (HL MK-2 only); Fiberglass enclosure (OL)
Cable:	12 ft (3.6m), 22 awg co-ax / 18 awg wire
Max Bin Temp:	Ryton® probe: 450° F (+232° C); Nylon: 300° F (+148° C)

Ryton® - Trademark of Phillips Chemical Co.

Teflon® - Trademark of DuPont Chemical Co.

## MK-2 SPECIFICATIONS

<b>Power:</b>	48-240VAC ±10%, 3VA, 50/60Hz; 24-48VDC ±10%, 3W
<b>Altitude:</b>	6562ft (2000m) max
<b>Installation Category:</b>	II
<b>Pollution Degree:</b>	4 (reduced to 2 by enclosure) Suitable for indoor/outdoor use
<b>Ambient Op Temp:</b>	-40° F (-40° C) to +150° F (+65° C)
<b>*Internal Bin Temp:</b>	To +176° F (+80° C) w/alum. mount (<104° F (40° C) ambient); To +400° F (+204° C) w/SS mount (<122° F (50° C) ambient)
<b>Output Relay:</b>	DPDT, 5A @ 250VAC, 30VDC maximum
<b>Indicators:</b>	"DET" yellow LED illuminates when material is sensed "OPR" red LED illuminates to indicate output switching "CAL" green LED illuminates to indicate proper calibration "SEN" bank of four LEDs indicate the sensitivity setting
<b>External Indicators:</b>	Red and green LEDs indicating power and operating mode(Ordinary location units only)
<b>Sensitivity:</b>	Switch selectable 0.5pf, 2.6pf, 8.3pf, 18.0pf
<b>Stability:</b>	±0.01pf per degree F (±0.018pf per degree C) @ 0.5pf setting
<b>Time Delay:</b>	0.25 to 15 sec single-turn adj. for delay to activate & delay to de-activate
<b>Fail-Safe:</b>	Switch selectable - HI/LO



<b>Build-up Immunity:</b>	Protected via driven shield to 150 ohm load
<b>Enclosure:</b>	Cast alum screw-on cover, beige polyester pwdr coat, NEMA 4X, IP66
<b>Conduit Connection:</b>	Two (2) 3/4" NPT connections (M20 cable glands provided when 1-1/2" BSPT process connection is specified)
<b>**Approvals:</b>	CSA <sub>US</sub> CSA <sub>C</sub> Ordinary Locations, CE Mark(Ordinary location only) CSA <sub>US</sub> CSA <sub>C</sub> : Class I Groups C & D, Exp. Proof & Intrinsically Safe CSA <sub>US</sub> CSA <sub>C</sub> : Class II Group E, F & G, Dust Ignition Proof & Intrinsically Safe

## MK-2e SPECIFICATIONS

<b>Power:</b>	115VAC (±15%); 2.5VA; 50/60Hz / 230VAC (±15%); 2.5VA; 50/60Hz 24VDC (±15%); 3W (24VDC not available on Remote Elec or Haz Loc Approval)
<b>Altitude:</b>	6562 ft (2000 m) max
<b>Installation Category:</b>	II
<b>Pollution Degree:</b>	4 (reduced to 2 by enclosure) Suitable for indoor/outdoor use
<b>Ambient Op Temp:</b>	-40° F (-40° C) to +150° F (+65° C)
<b>*Internal Bin Temp:</b>	To +176° F (+80° C) w/alum. mount (<104° F (40° C) ambient); To +400° F (+204° C) w/SS mount (<122° F (50° C) ambient)
<b>Output Relay:</b>	SPDT, 5A @ 250VAC, 30VDC maximum
<b>External Indicators:</b>	Red and green LEDs indicating power and operating mode (Ordinary location units only)
<b>Sensitivity:</b>	Multi-turn potentiometer adjustment 0.5pf to 150 pf
<b>Stability:</b>	±0.015pf per degree F (±0.027pf per degree C) @ 0.5pf setting
<b>Time Delay:</b>	0.25 to 15 sec delay-to-activate, adjustable 0.25 sec delay-to-deactivate, fixed
<b>Fail-Safe:</b>	Switch selectable - HI/LO
<b>Build-up Immunity:</b>	Protected via driven shield to 150 ohm load
<b>Enclosure:</b>	Cast alum screw-on cover, beige polyester pwdr coat, NEMA 4X, IP66
<b>Conduit Connection:</b>	Two (2) 3/4" NPT connections (M20 cable glands provided when 1-1/2" BSPT process connection is specified)
<b>**Approvals:</b>	CSA <sub>US</sub> CSA <sub>C</sub> Ordinary Locations, CE Mark(Ordinary location only) CSA <sub>US</sub> CSA <sub>C</sub> : Class I Groups C & D, Exp. Proof & Intrinsically Safe CSA <sub>US</sub> CSA <sub>C</sub> : Class II Group E, F & G, Dust Ignition Proof & Intrinsically Safe

\* Influenced by mounting, material thermal conductivity and ambient temperature.

\*\* Hazardous location approvals on units with Pipe Extension or Lagged Probes with integral electronics/probe are CSA<sub>US/C</sub> Class II Group E, F & G (SS version ONLY). Hazardous location approvals are not available on the galvanized version). Hazardous location approvals for Split Architecture remote electronics are Class II, Groups E, F & G. Hazardous location approval not available on split architecture version of model MK-2e. All probe versions, except the galvanized version of the pipe extension or lagged probe unit, are Class I Groups C & D, Class II Group E, F & G and Intrinsically Safe.

## WARRANTY

Monitor Technologies LLC warrants each **TrueCap**<sup>®</sup> RF capacitance sensor it manufactures to be free from defects in material and workmanship under normal use and service for two (2) years from the date of purchase. The purchaser must notify Monitor of any defects within the warranty period, return the product intact, and prepay transportation charges. The obligation of Monitor Technologies LLC under this warranty is limited to repair or replacement at its factory. This warranty does not apply to any product which is repaired or altered outside of Monitor Technologies' factory, or which has been subject to misuse, negligence, accident, incorrect wiring by others, or improper installation.





Huntsman, Inc. ▼ 2362 Warren Ave. ▼ Twin Falls, Idaho 83301 ▼ (877) 733-2214 ▼ (208) 733-2214 ▼ Fax (208) 733-2240  
[www.huntsmaninc.com](http://www.huntsmaninc.com) ▼ [mail@huntsmaninc.com](mailto:mail@huntsmaninc.com)

