

Mulch

Compost

Rock

Soil

JEM
International, Inc.
Distributors of ESP Equipment

A complete bagging system designed for handling a variety of lawn and garden products.

MCRS 180

A one man operation rated at 3 bags per minute. The system consists of an infeed hopper, incline conveyor, weighing system and a bag closing system.

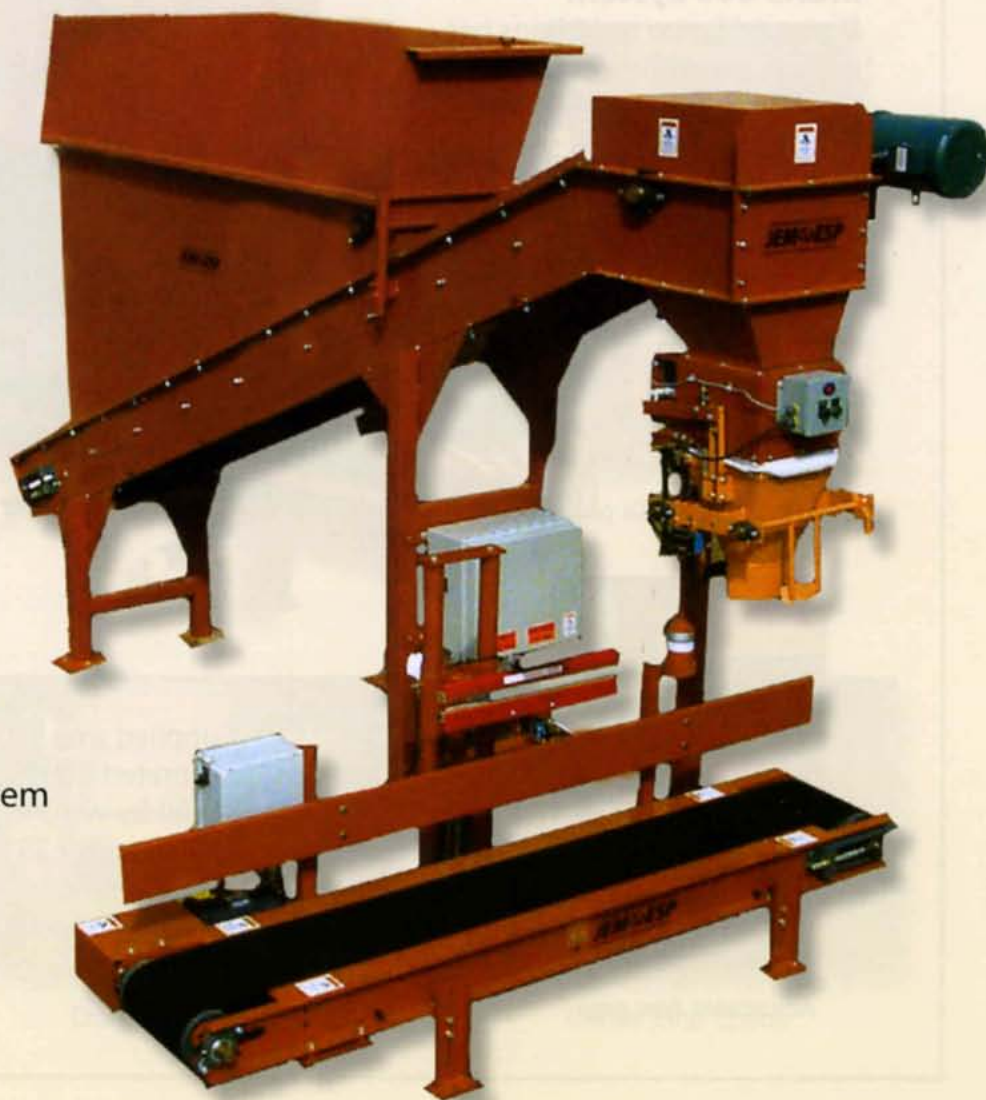

MCRS systems are designed for handling a variety of lawn and garden products. Typical products include rubber mulch, wood mulch, all varieties of rock up to 3/4" in size, top soil, compost, sandy loam and sand.



1.5 cubic yard feed hopper (1 cu. meter)



System being loaded by a Bobcat



Cleated, incline belt and agitator

MCRS 600 System

Designed for up to 10 bags per minute, depending on the product and bag size. Shown with a Packrite Bandrite heat sealer.



Adjustable flow gate

Supplied with 5:1 calibrated beam for fill-by-weight, shown with a 25" circumference center grip spout.





MCRS 600 shown with Optional Incline Conveyor

Available Options



Flattening Conveyor



Bag Turning Conveyor



Bag Kicking Conveyor



Clam Shell Spout



Dust Tight Spout



Center Grip Spout

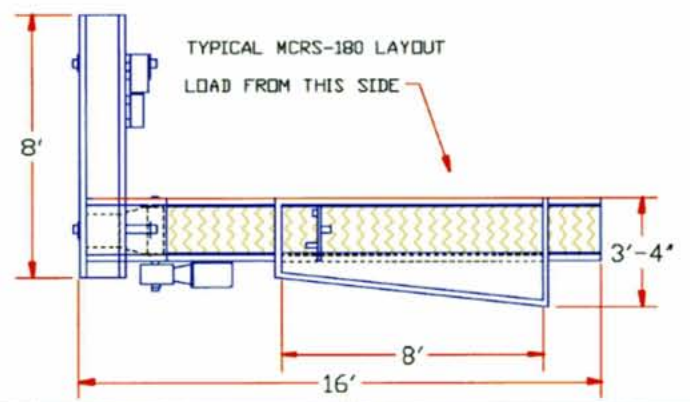
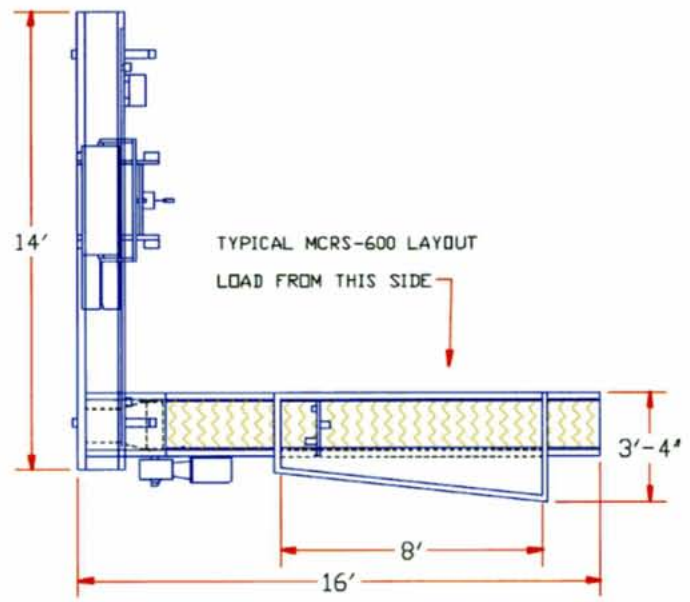
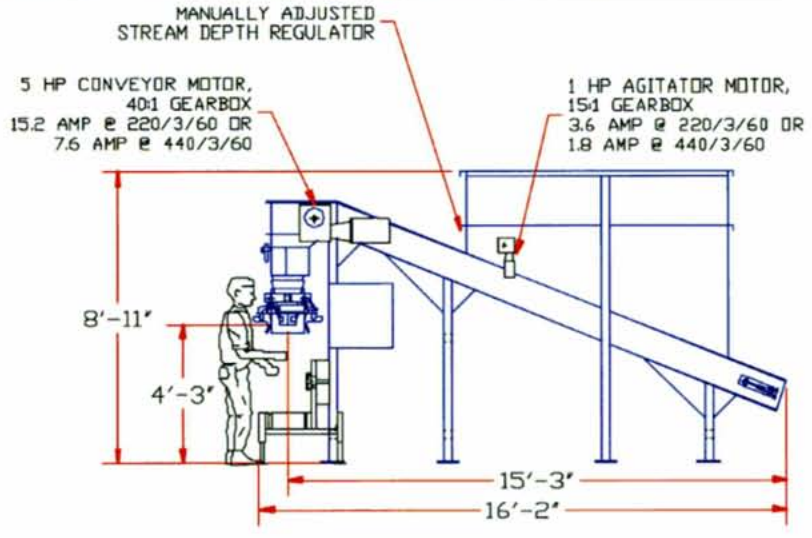

Huntsman, Inc.

2362 Warren Ave. Twin Falls, Idaho 83301
 (877) 733-2214 (208) 733-2214 Fax (208) 733-2240
 www.huntsmaninc.com mail@huntsmaninc.com