



J-Series

High Pressure (to 5,000 PSIG) Compressed Gas Filters

Finite's "J" Series housings provide much needed filtration protection for high pressure systems.

The filter elements are metal reinforced for demanding applications.

The threaded head-to-bowl design makes servicing easy.

All assemblies are supplied with drain ports making bowl sump draining an easy task.



Finite®

Huntsman, Inc.

2362 Warren Ave
Twin Falls, ID 83301

mail@huntsmaninc.com

www.huntsmaninc.com

(888) 812-3377

J-Series High Pressure Filters

High Pressure Systems Need Filtration Protection

High pressure compressed gas systems pose difficult problems that require special filtration attention. Excessive amounts of liquid aerosols and solid particulate contamination are common. In addition, higher temperature levels are possible, and may cause the liquid oils to varnish. Varnishing contributes to poor component performance and wear that may lead to unscheduled maintenance. Finite's "J" Series high pressure filters are an extremely effective way to reduce or eliminate these problems.

Removing Liquid Aerosols

Finite's Grade 4 media will remove 99.995% of liquid aerosols in the .3 to .6 micron range. For most systems the Grade 4 coalescing media is recommended. But for systems with high liquid concentrations (+ 50 ppm of oil or + 25 ppm of water), pre-coalescing is required.

Pre-coalescing involves two-stage filtration. A Finite "J" Series filter with Grade 10 media is used to remove the gross aerosols. Then a second "J" Series filter with Grade 4 media is placed after the Grade 10 filter to clean up the remaining aerosols.

Filtering Solid Particulates

Particulate contamination problems are controlled and often eliminated with Finite's "3P" pleated cellulose media. The pleated element exposes a larger surface area that significantly increases element life. Finite's resin impregnated "3P" media is also water resistant giving it high performance in the presence of liquids.

Particulate filter elements like the "3P" are often used upstream of coalescing filters. By removing particulate contamination first, the life of the coalescing filter is greatly extended.

Specifications

Housing Model	J2SD	J2SL	J4SF	J4NF	J6SH	J6NH
Port Size	SAE-8 (Std.) Adapter Bushings Provided for 1/2" NPT Female		SAE-16	1" NPT	SAE-24	1½" NPT
Pressure (PSIG), Max.	5000		5000		5000	
Temp. (°F), Max.	350		350		350	
Sump Capacity	60 ml	220 ml	210 ml		637 ml	
Assembly Weight (lbs.)	9.2	13.1	22.1		52.5	
Major Materials of Construction (with coalescing element installed)	Ductile iron, fluoro-carbon seals, aluminum, fiberglass, carbon steel, epoxy, rayon.		Nodular cast iron, carbon steel, fluoro-carbon seals, fiberglass, epoxy, rayon, aluminum, engineered plastic.		Nodular cast iron, carbon steel, fluoro-carbon seals, fiberglass, epoxy, rayon, aluminum.	
Drain Port Size	SAE-6		SAE-6		SAE-6	

J-Series High Pressure Filters

Application Notes

- At high pressures, excessive amounts of oil aerosols may be present. Pre-coalescing with Grade 10 may be necessary before final coalescing.
- Grade 4 (not Grade 6 as in other Finite Filter series) is used as the standard coalescer media in the "J" Series. High pressure systems reduce the effectiveness of filter media, requiring the upgrade to Grade 4 media as the standard.
- Flow Direction:

Coalescers (Grade 10 or Grade 4)	Port 1 to Port 2
Interceptors ("3P" Particulate)	Port 2 to Port 1
Absorbers ("A" Charcoal Adsorber)	Port 2 to Port 1
- Element Replacement:

	Element Differential Pressure (PSID)
Coalescers and Particulate Interceptors	10
Absorbers	Any Increase, or after 6 months in use.
- Mount filters in a vertical position.
- Do not service these filters under pressure!** The system pressure must be reduced to atmospheric levels before changing elements, draining bowls, or performing any other maintenance activity on or near these filters.

Flow Rates (SCFM @ indicated system pressures)

	Media	J2SD & J2SL	J4SF & J4NF	J6SH & J6NH
Flow @ 1500 PSIG	4C, A	400	1000	3000
	10C, 3P	800	2000	6000
Flow @ 3000 PSIG	4C, A	800	2000	6000
	10C, 3P	1600	4000	12,000
Flow @ 4500 PSIG	4C, A	1200	3000	9000
	10C, 3P	2400	6000	18,000

Dimensions (In Inches)

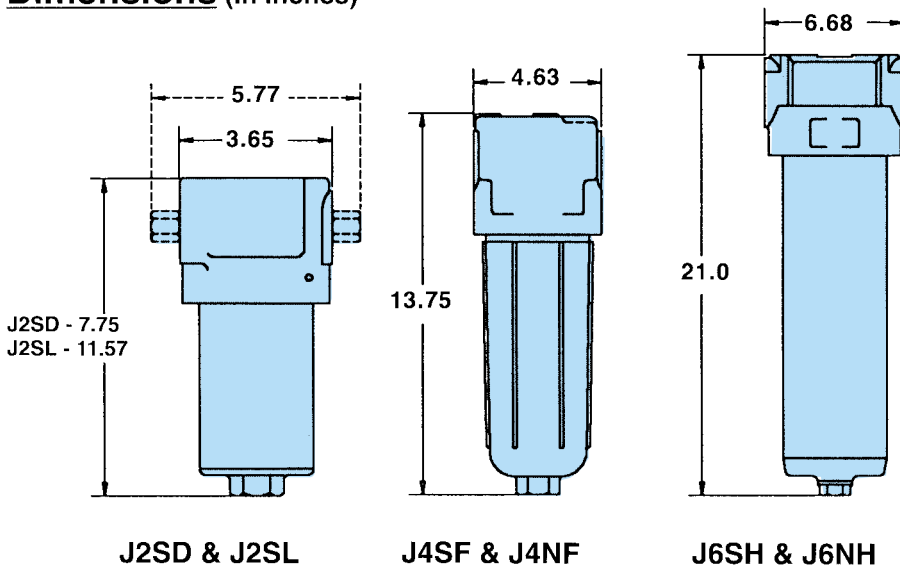

How To Order

Housing Information — Element Information

J 4S F - 4 C WC 15 - 070

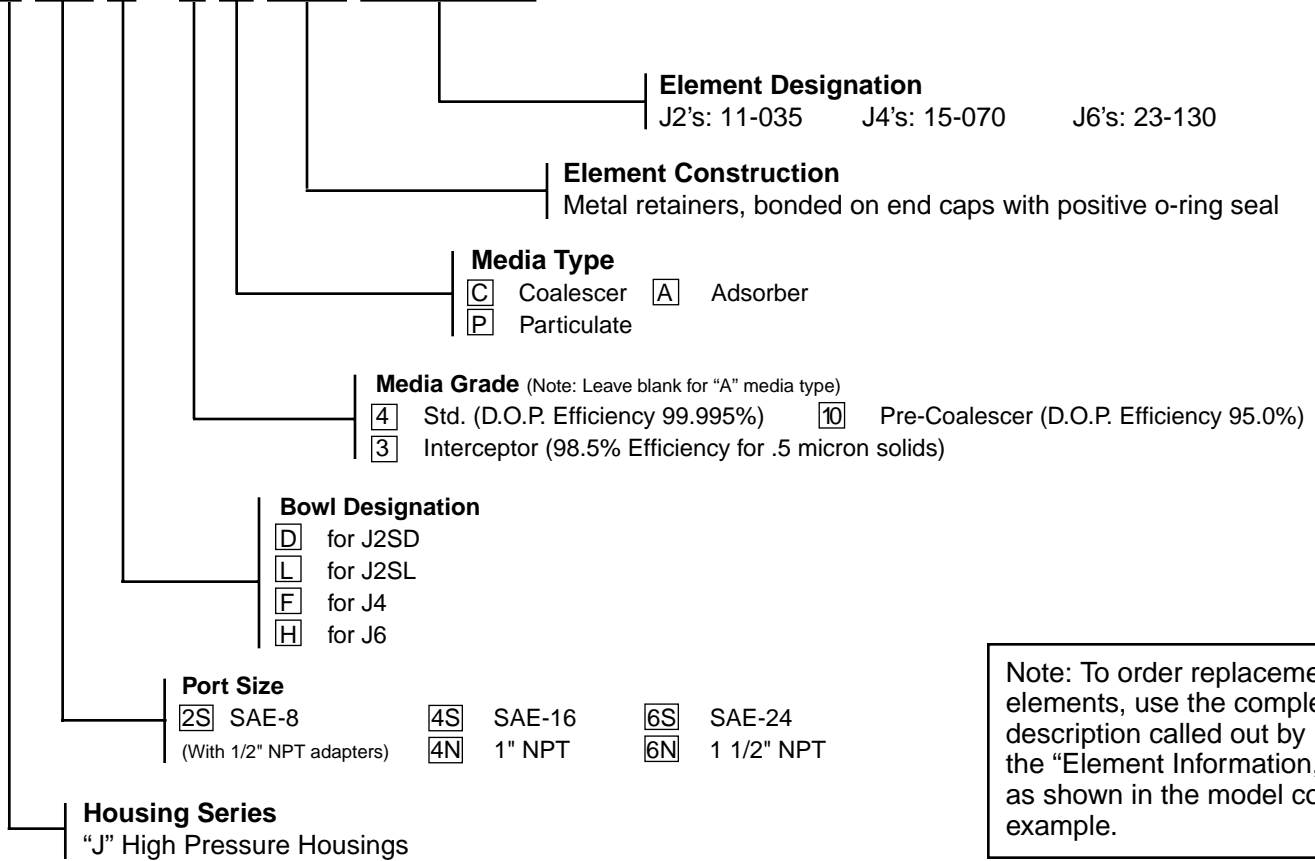

Note: To order replacement elements, use the complete description called out by the "Element Information," as shown in the model code example.

WARNING

FAILURE OR IMPROPER SELECTION OR IMPROPER USE OF THE PRODUCTS AND/OR SYSTEMS DESCRIBED HEREIN OR RELATED ITEMS CAN CAUSE DEATH, PERSONAL INJURY AND PROPERTY DAMAGE.

This document and other information from Parker Hannifin Corporation, its subsidiaries and authorized distributors provide product and/or system options for further investigation by users having technical expertise. It is important that you analyze all aspects of your application including consequences of any failure, and review the information concerning the product or system in the current product catalog. Due to the variety of operating conditions and applications for these products or systems, the user, through its own analysis and testing is solely responsible for making the final selection of the products and systems and assuring that all performance, safety and warning requirements of the application are met.

The products described herein, including without limitation, product features, specifications, designs, availability and pricing are subject to change by Parker Hannifin Corporation and its subsidiaries at any time without notice.