

# BULLETIN 634

## INSTALLATION & OPERATION

### Tilt Switch Level Monitors



Thank you for purchasing a quality product manufactured by Monitor Technologies LLC. We realize that you do have a choice of vendors when procuring rotary paddle bin level monitors and we sincerely appreciate your business!



This manual contains the information necessary to ensure a safe and successful installation. Please read and comply with the section on page 4 of this manual pertaining to SAFETY. Doing so will ensure proper operation of the equipment and the safety of all personnel.



Before discarding shipping container, please inspect it thoroughly and verify that all parts ordered are accounted for. Sometimes smaller parts become stuck under carton flaps and other packaging materials.

In the event that information contained herein does not completely satisfy your requirements or answer your questions, you may contact Technical Support on our website [www.monitortech.com](http://www.monitortech.com), by telephone at 800-766-6486 (630-365-9403), or by fax at 630-365-5646. If your KA/KAX ever requires service either in or out of warranty, please contact us and obtain an RMA number prior to shipping the unit to us.



**HUNTSMAN, INC**  
*Packaging, Processing and Dust Control*

2362 Warren Ave.  
Twin Falls, ID 83301  
[mail@huntsmainc.com](mailto:mail@huntsmainc.com)

Ph. (208) 733-2214  
Toll Free: (888) 812-3377  
Fax: (208) 733-2240

## PRE-INSTALLATION CONSIDERATIONS

### Choosing a Location (See Figure 1)

- Free movement:** Select a location where any movement of the tilt switch is not impeded by structural components such as vessel braces or side walls. Insure the electrical connection does not impede the the tilting action of the tilt switch when sensing material.
- Material contact:** Do not locate the tilt switch in the direct flow of material as this may cause false signals or physical damage to the enclosure or the electrical connections. Select a hanging location where the application permits the tilt switch to "tilt" at least 17° from vertical when "sensing" is to be indicated. Consider whether extension actuators are required. If the anticipated angle of deflection approximates 17° (hence very repeatable sensing is required), or if material is very coarse, thereby potentially causing physical damage, attach an extension actuator to protect the tilt switch (See Mechanical Installation).

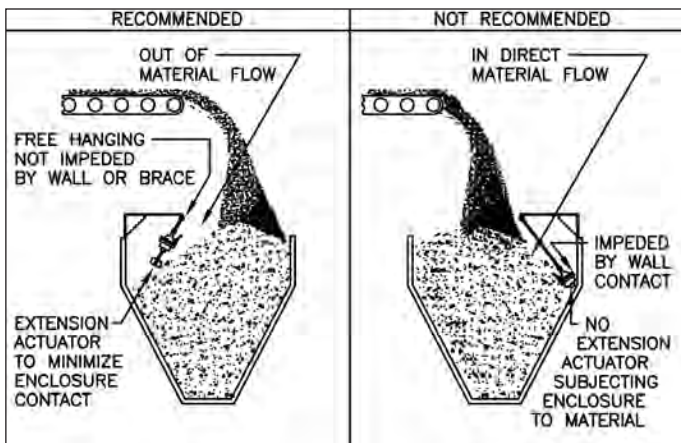

Figure 1

## MECHANICAL INSTALLATION

### ⚠ Suspension of Tilt Switch (See Figure 2)

Locate or fabricate a structural brace to support the full weight of a suspended tilt switch (and extension actuator if used). Interconnect the structural brace and the tilt switch with a rigid or flexible hanger (e.g. wire rope, chain). Never hang tilt switch by its electrical cable. Ensure installation permits the switch to "tilt" at least 17° from vertical when "sensing" is to be indicated.

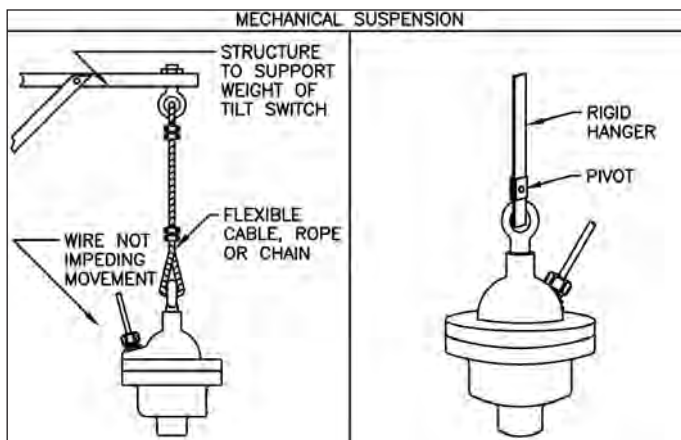

Figure 2

### Using Extension Actuators (See Figure 3)

Each tilt switch has a threaded bore on the assembly's bottom where an extension actuator can be attached. The extension actuator can be fabricated from pipe and steel sheet and then screwed into the tilt switch. Length and vane size can be determined by the user as required by the application. The extension actuators can improve tilt switch operation in two ways:

- Improve repeatability of detection angle:** Material can create a more consistent physical deflection when contacting the vanes of an extension actuator than when contacting the enclosure wall of the tilt switch.
- Protection against physical wear:** Extending the tilt switch away from the initial contact with the "sensed" material will prevent potential damage to the tilt switch.

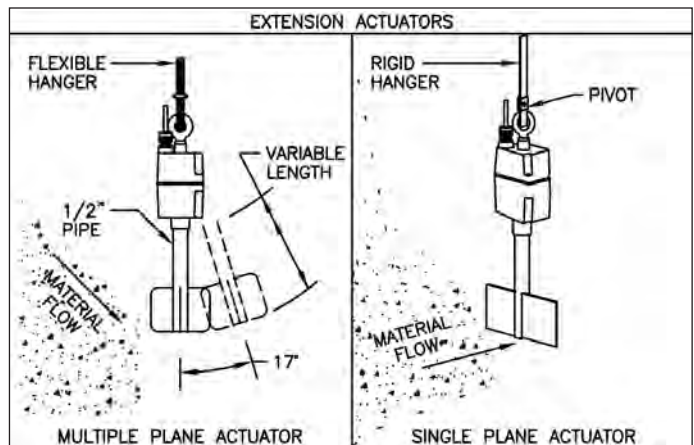

Figure 3

## ELECTRICAL INSTALLATION

### Hazardous Location Precautions

When installing a TC-3X, observe the regulations listed in the National Electrical Code regarding equipment in hazardous locations. In particular, ensure power is disconnected whenever the enclosure is opened, ensure the joints of the enclosure halves and gasket are not damaged, and upon reassembly, ensure interconnection screws are secure.

### ⚠ Output Contacts (See Figure 4)

Each tilt switch has a cord connector sized to accept an electrical cord with a diameter of 0.25-0.38in (6.4-9.6mm). Select a cord rated for "extra hard usage" (e.g. SO or STO ratings). Guide cord through the cord connector and tighten to insure dust-tight and water-tight protection. If it is desirable to use conduit, remove cord connector to expose threaded conduit entry in enclosure body. Use at least two feet of flexible conduit. Never connect rigid conduit directly to the tilt switch. Verify tilting action is not impeded under normal sensing conditions. No power is required to operate the tilt switches. Electrical installation is done directly to the terminals of the output switch within the enclosure. The terminals are designated with COM-common, N.C.-normally closed, and N.O.-normally open. When the switch is "not tilted," the switch is opposite from normal condition (i.e. N.C. contact is open to COM, and N.O. contact is closed to COM). However, when the tilt switch is "tilted" the switch is in the normal condition (i.e. N.C. contact is closed to COM, and N.O. contact is open to COM). Connect earth ground to the terminal located on the lower enclosure half. Be sure to comply with all electrical specifications.

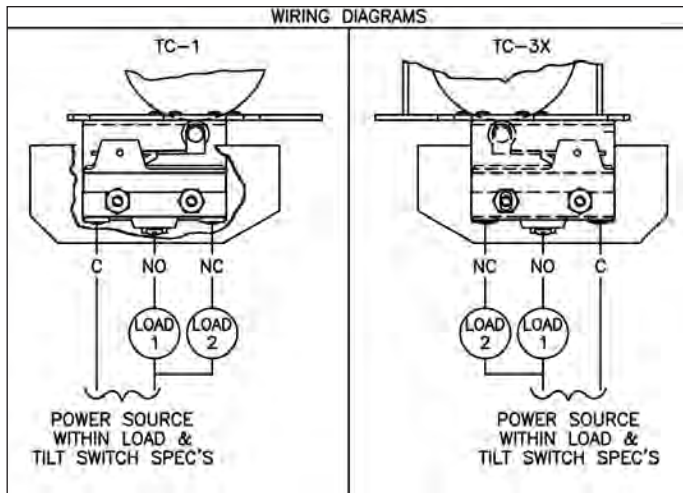

Figure 4

## TROUBLESHOOTING

**PROBLEM: The tilt switch does not indicate material sensing.**

**CAUSE/SOLUTION:**

- 1) Verify material is contacting the tilt switch or its extension actuator. If necessary, reposition tilt switch.
- 2) Verify a sufficient angle (equal or greater than 17° from vertical) is achieved when material is to be sensed. If necessary, remount per Mechanical Installation section.
- 3) Verify that the hanging mechanism (wire rope, chain, etc.) and the electrical cable are not restricting the angular movement of the tilt switch body. If necessary, modify hanging or electrical connection.
- 4) Verify electrical connection. When in non-material sensed mode (not tilted) the N.O. contact is closed to COM, and the N.C. contact is open to COM. If necessary, change wiring orientation.
- 5) Verify that the internal steel ball deactivates the switch when rolled off center between each set of dimples. If necessary, adjust position of internal switch per Maintenance section.

**PROBLEM: The tilt switch always indicates material is sensed.**

**CAUSE/SOLUTION:**

- 1) Verify material falls completely away from the tilt switch and its extension actuator. If necessary, reposition tilt switch to assure return to vertical status.
- 2) Verify that the hanging mechanism (wire rope, chain, etc.) and the electrical cable are not restricting the tilt switch from returning to vertical status. If necessary, modify hanging or electrical connection.
- 3) Verify electrical connection. When in material sensed mode (tilted) the N.O. contact is open to COM, and the N.C. contact is closed to COM. If necessary, change wiring orientation.
- 4) Verify that the internal steel ball actuates the switch when positioned in the center of the cage. If necessary, adjust position of internal switch per Maintenance section.

## CALIBRATION

The tilt switches require no calibration or setup in the field. Each tilt switch is factory set to provide indication whenever the enclosure is tilted at 17° or greater from the vertical axis. Each unit will actuate at the 17° tilt angle throughout the complete 360° of axial arc. If an internal switch is replaced, see Maintenance section for proper adjustment.

## MAINTENANCE

**Switch Replacement/Positioning (See Figure 5)**

- 1) Remove power from the wires connected to the tilt switch. Remove tilt switch from installation.
- 2) Open assembly by removing screws holding upper and lower enclosure halves. Remove switch.
- 3) Mount new switch using the same hardware. Position switch so the following conditions are met:
  - a) Achieve distance between switch body and mounting frame as noted in drawing below.
  - b) Switch should activate when steel ball is placed in the center of the cage.
  - c) Switch should deactivate when steel ball rolls off center between each set of dimples.
- 4) Reattach wires as required. Reassemble upper and lower enclosure halves. Test operation to insure switch activates/deactivates at 17° angle.

DIMENSIONS ARE SHOWN IN INCHES WITH MILLIMETER EQUIVALENT IN BRACKETS

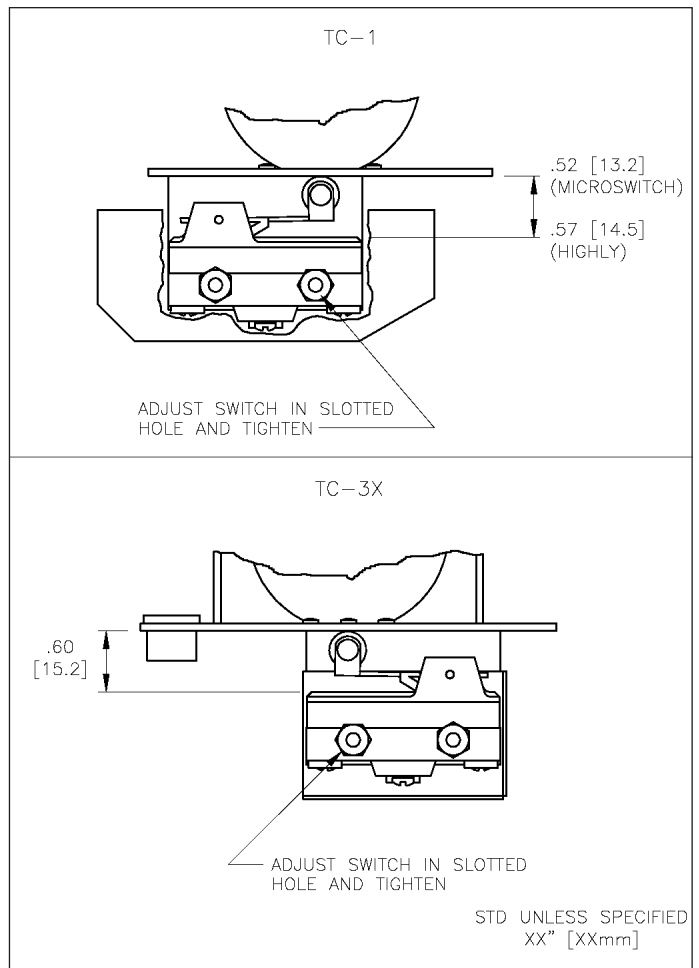

Figure 5

## SAFETY

### ⚠ General Safety

**CAUTION:** It is essential that all instructions in this manual be followed to ensure proper operation of the equipment and safety of operating personnel. The use of this symbol is used throughout this manual to highlight important safety issues. Please pay particular attention to these items.

### ⚠ Electrical Shock Caution

All tilt switches may be configured to “switch” HIGH VOLTAGE depending on the application requirements. To avoid electrical shock, remove power before opening enclosure. Each unit is provided with a “protective ground” connection which shall be terminated to earth ground potential. This terminal shall be used to eliminate shock hazard in the unlikely event of internal insulation breakdown.

### Hazardous Location Caution

Model TC-3X is “approved” for use in certain Hazardous Locations (see specifications). These products shall only be used in applications covered by these ratings or those considered non-hazardous. Failure to comply could result in catastrophic damage to personnel and property. The following must be maintained to assure safe operation:

- 1) **Enclosure integrity:** The dimensions enclosure shall not be altered. The gasket shall be used and not altered. Proper sized cord shall be used to insure dust exclusion at electrical connection.
- 2) **Maintenance:** Disassembly of the enclosure to conduct maintenance while power is yet supplied does not meet hazardous location requirements. If done, it is at the risk of the customer only.

## WARRANTY

Monitor Technologies LLC warrants each tilt switch it manufactures to be free from defects in material and workmanship under normal use and service within two (2) years from the date of purchase. The purchaser must give notice of any defect to Monitor within the warranty period, return the product intact and prepay transportation charges. The obligation of Monitor Technologies LLC under this warranty is limited to repair or replacement at its factory. This warranty shall not apply to any product which is repaired or altered outside of the Monitor Technologies LLC factory, or which has been subject to misuse, negligence, accident, incorrect wiring by others or improper installation. Monitor Technologies LLC reserves the right to change the design and/or specifications without prior notice.

## MECHANICALS

DIMENSIONS ARE SHOWN IN INCHES WITH MILLIMETER EQUIVALENT IN BRACKETS

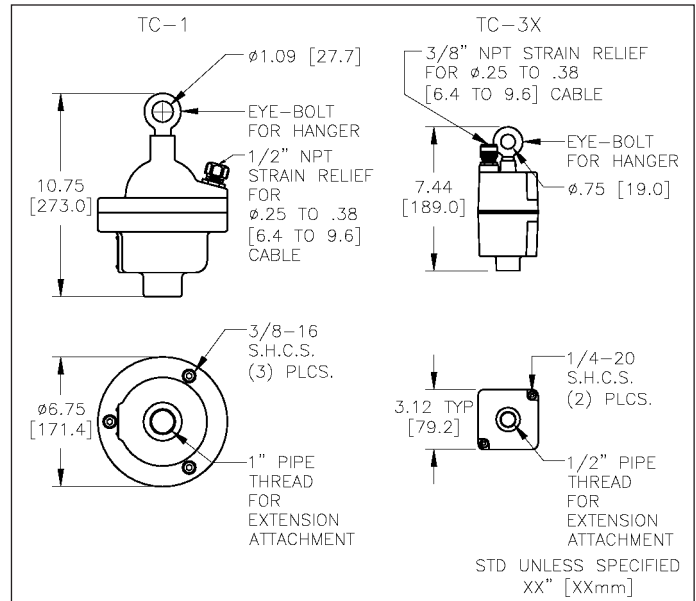

## SPECIFICATIONS

### Model TC-3X

Power Requirements: None  
 Output: SPDT, 10A @ 250 VAC max  
 Sensitivity: 17° from vertical axis  
 Enclosure: Cast aluminum, unpainted  
 Enclosure Protection: NEMA 4, IP56  
 Mounting Connection: Eyebolt, 3/4in (19mm) dia  
 Wire Entry: 3/8" NPT cord connector  
 Cord dia 0.25-0.38in (6.4-9.6mm)  
 Operating Temperature: -40° to 175° F (-40° to 80° C)  
 Weight: 3lb (1.4kg)  
 Approvals: FM Class II, Div 1,2 Groups E,F,G  
 CE Mark

### Model TC-1

Power Requirements: None  
 Output: SPDT, 15A @ 250 VAC max  
 Sensitivity: 17° from vertical axis  
 Enclosure: Cast iron, painted beige  
 Enclosure Protection: NEMA 4, IP56  
 Mounting Connection: Eyebolt, 1-3/32in (27.7mm) dia  
 Wire Entry: 1/2" NPT cord connector  
 Cord dia 0.25-0.38in (6.4-9.6mm)  
 Operating Temperature: -40° to 250° F (-40° to 121° C)  
 Weight: 24lb (11kg)  
 Approvals: CE Mark