

BULLETIN 464A

INSTALLATION & OPERATION

TrueCap[®] RF Capacitance Level Sensor Model MK-2e



Thank you for purchasing a quality product manufactured by Monitor Technologies LLC. We realize that you do have a choice of vendors when procuring RF Capacitance sensors and we sincerely appreciate your business!



This manual contains the information necessary to ensure a safe and successful installation. Please read and comply with the section on page 10 of this manual pertaining to SAFETY. Doing so will ensure proper operation of the equipment and the safety of all personnel.



Before discarding shipping container, please inspect it thoroughly and verify that all parts ordered are accounted for. Sometimes smaller parts become stuck under carton flaps and other packaging materials.

In the event that information contained herein does not completely satisfy your requirements or answer your questions, you may contact Technical Support on our website www.monitortech.com, by telephone at 800-766-6486 (630-365-9403), or by fax at 630-365-5646. If your sensor ever requires service either in or out of warranty, please contact us and obtain an RMA number prior to shipping the unit to us.

HUNTSMAN, INC
Packaging, Processing and Dust Control

2362 Warren Ave.
Twin Falls, ID 83301
mail@huntsmainc.com

Ph. (208) 733-2214
Toll Free: (888) 812-3377
Fax: (208) 733-2240

PRE-INSTALLATION CONSIDERATIONS

Choosing a Location: (See Figure 2)

- 1) **Material Flow** - When selecting a location for the MK-2e, choose a point in the vessel where the probe will be out of the direct flow of incoming and outgoing material to prevent any mechanical damage that may be caused by the pressure of the flow. The MK-2e must be positioned at a point where incoming material will reach and cover the probe in its normal flow, and when receding, will flow away from the probe in an even manner. For best results, choose a position where a majority of the probe, not just the tip, will be covered. This is particularly important when detecting materials with low relative dielectric constants and low product densities. The unit will not operate as a "tip sensitive" device. For extended length models, allow for at least 8 to 12 inches (203-305 mm) of probe coverage. When sensing highly conductive materials, or those with a high dielectric constant, the MK-2e can perform as a "tip sensitive" sensor.
- 2) **Vessel Contact** - Select an area where the probe can not contact any internal structure elements of the vessel. When using the Cable Extension Probe, consider the angle of repose of the material that will flow into and out of the vessel. Insure that the expected swing of the cable will not touch the vessel.
- 3) **Driven Shield Penetration** - Select a location which ensures that the driven shield section protrudes into the vessel and is not recessed in the mounting neck.
- 4) **Multiple Probe Proximity** - If more than one sensor is mounted in the vessel, do not place the sensors closer than 18 inches (457 mm) from one another.
- 5) **Pipe Extension Reinforcement** - When top mounting a probe with a pipe extension, select a location where it is feasible to reinforce the extension to the vessel wall. See Mechanical Installation portion of this bulletin for details.
- 6) **Split Architecture Installation** - When installing a sensor with a remote probe, the restrictions above apply to the remote probe. The remote electronics can be installed either horizontally or vertically. The remote electronics must be located within 12 feet (3.6 m) (wiring distance) of the probe at a location that is free from excessive heat and/or vibration.

Cover Removal: (See Figure 1)

Before loosening the cover, loosen or remove the cover lock screw. Spanner slots are incorporated on the top of the cover which should be used to loosen the cover from the housing. Use a flat bar for initial loosening. DO NOT use a strap or chain type wrench. Keep hands clear of threads on the cover and housing to avoid contact with the thread lubricant.

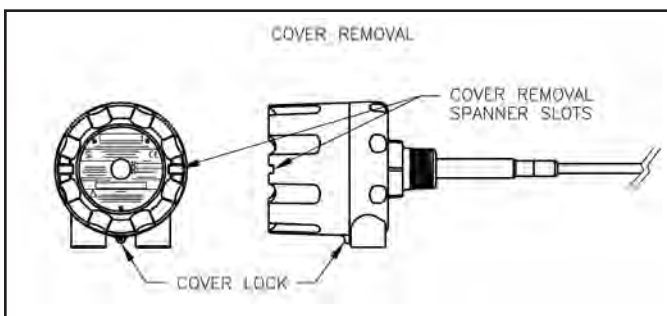

Figure 1

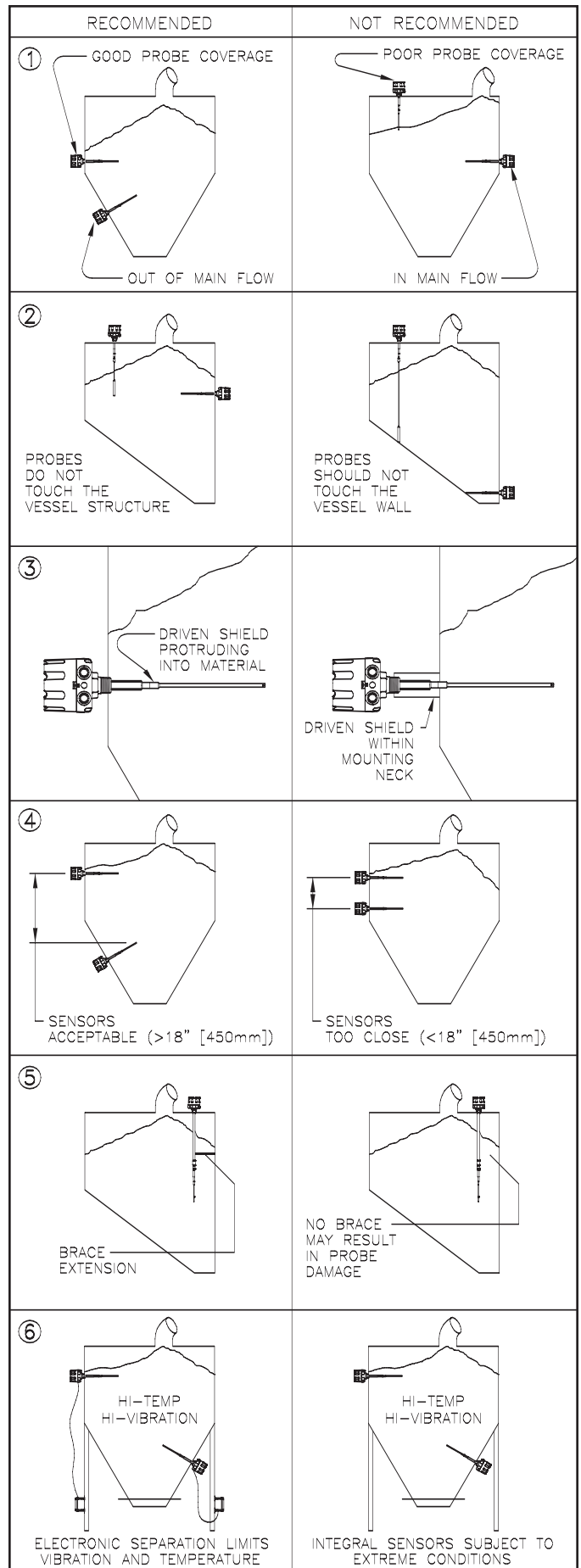

Figure 2

MECHANICAL INSTALLATION

Standard, Food Grade, Stub, Cable Extension and Remote Probe Mounting: (See Figures 3, 4 & 5)

- 1) Select a mounting location in accordance with the Pre-Installation Recommendations.
- 2) If using a welded fitting, cut a hole into the side/top of the vessel corresponding to the mounting connection (i.e. 1-1/2" BSPT, 1-1/4" NPT or 3/4" NPT). If using a Monitor mounting plate, cut a 2-1/2 inch (64 mm) center hole and six 11/32 inch (9 mm) mounting holes (for 5/16" bolts) on a 7 inch (178 mm) bolt circle. Use mounting plate as a template.
- 3) Weld fitting or attach mounting plate to vessel wall.
- 4) Insert probe through fitting. Do not use sealant tapes (e.g. Teflon tape) or putties. When using the 1-1/2" BSPT or 1-1/4" NPT connection, grease threads with anti-seize then thread unit tightly into place by gripping and rotating housing. When using the 3/4" NPT connection, thread unit tightly into place by gripping and rotating 15/16 inch (24 mm) wrench flats provided on fitting. Continuity between sensor mounting point and vessel wall must be maintained to assure proper probe operation.

DIMENSIONS ARE SHOWN IN INCHES WITH MILLIMETER EQUIVALENT IN BRACKETS

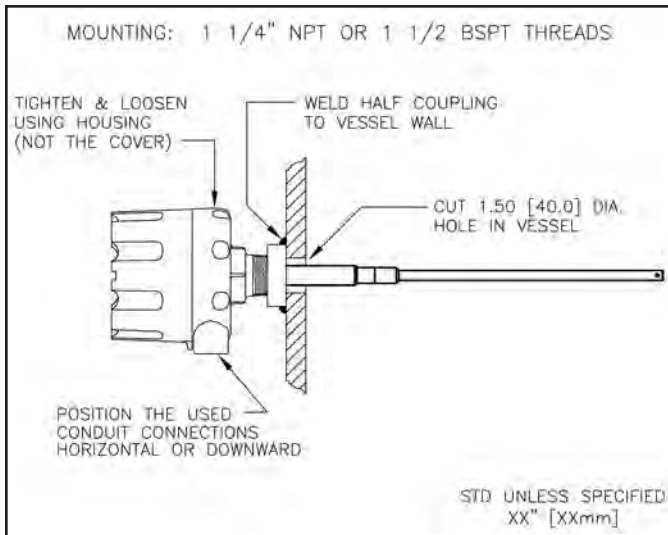

Figure 3

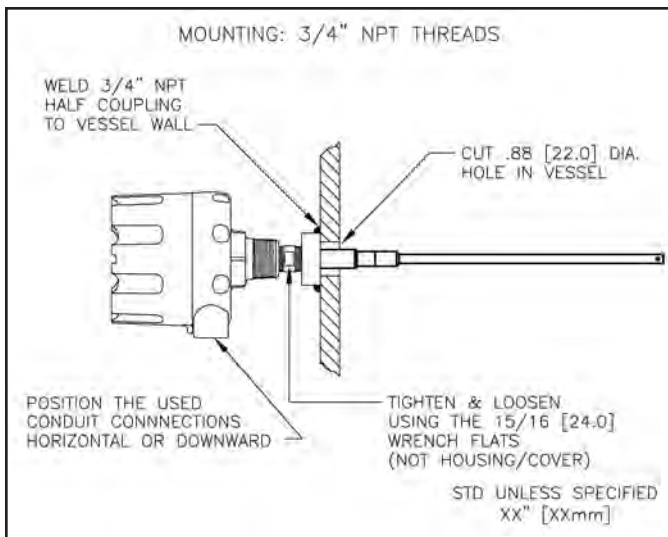

Figure 4

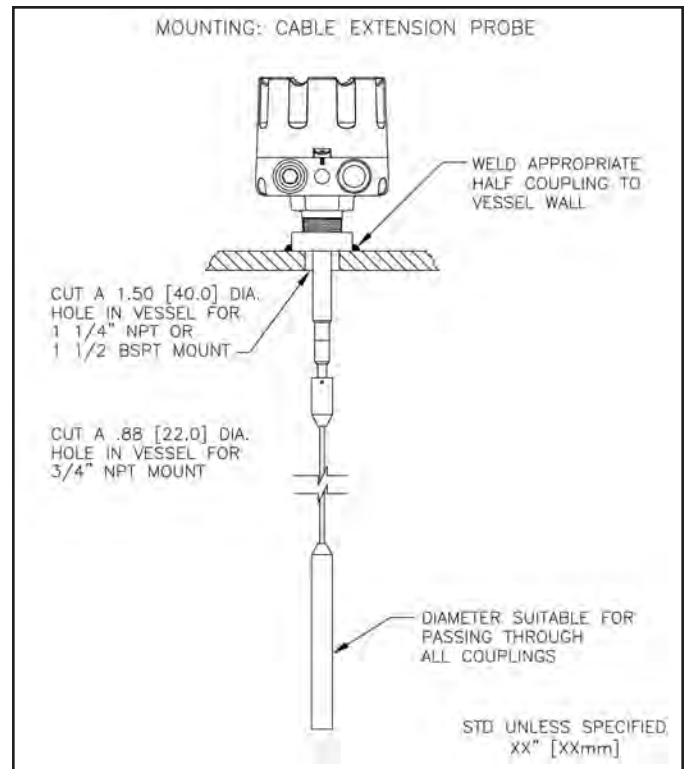

Figure 5

Lagged Housing Version Mounting: (See Figure 6)

- 1) Select a mounting location in accordance with the Pre-Installation Recommendations.
- 2) Cut a 7/8 inch (22 mm) hole into the side/top of the vessel corresponding to the 3/4" mounting connection used.
- 3) Weld fitting to the vessel wall.
- 4) Insert probe through fitting and thread unit tightly into place by gripping and rotating the 15/16 inch (24 mm) wrench flats provided on fitting closest to mounting point. Do not use sealant tapes (e.g. Teflon tape) or putties. If flats are inaccessible due to tank insulation, thread unit into place by gripping and rotating lagging pipe with a strap/pipe wrench. Continuity between sensor mounting point and vessel wall must be maintained to assure proper probe operation.

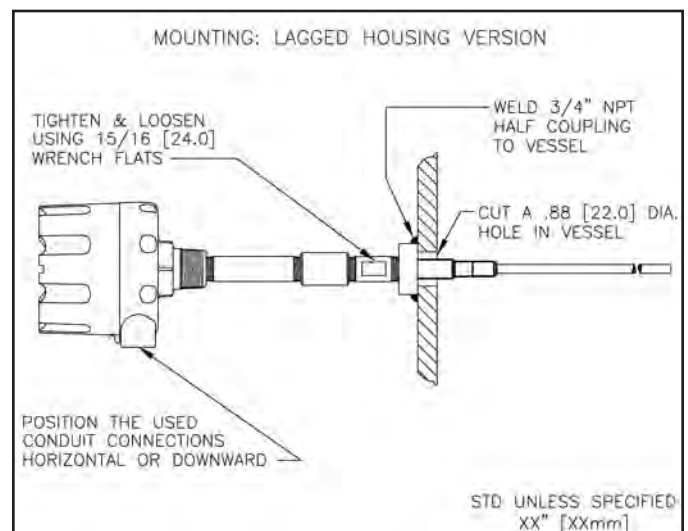

Figure 6

Pipe Extension Probe Mounting: (See Figure 7)

- 1) Select a mounting location in accordance with the Pre-Installation Recommendations.
- 2) If using a welded fitting, cut a 1-1/2 inch (40 mm) hole into the top of the vessel corresponding to the 1-1/4" mounting connection used. If using a Monitor mounting plate, cut a 2-1/2 inch (64 mm) center hole and six 11/32 inch (9 mm) mounting holes (for 5/16" bolts) on a 7 inch (178 mm) bolt circle. Use mounting plate as a template.
- 3) Weld fitting or attach mounting plate to vessel wall.
- 4) Insert probe through fitting, grease threads with anti-seize, then, thread unit tightly into place by gripping and rotating housing. Do not use sealant tapes (e.g. Teflon tape) or putties. Continuity between sensor mounting point and vessel wall must be maintained to assure proper probe operation.
- 5) Mechanical reinforcement of the pipe extension should be considered whenever the overall probe length (from mounting point to probe tip) exceeds 60 inches (1.5 m). Mechanical clamping, such as "U" or "C" channel with "U" bolts should be used. DO NOT USE HEAT to connect brace to pipe extensions as wiring inside pipe could be damaged.

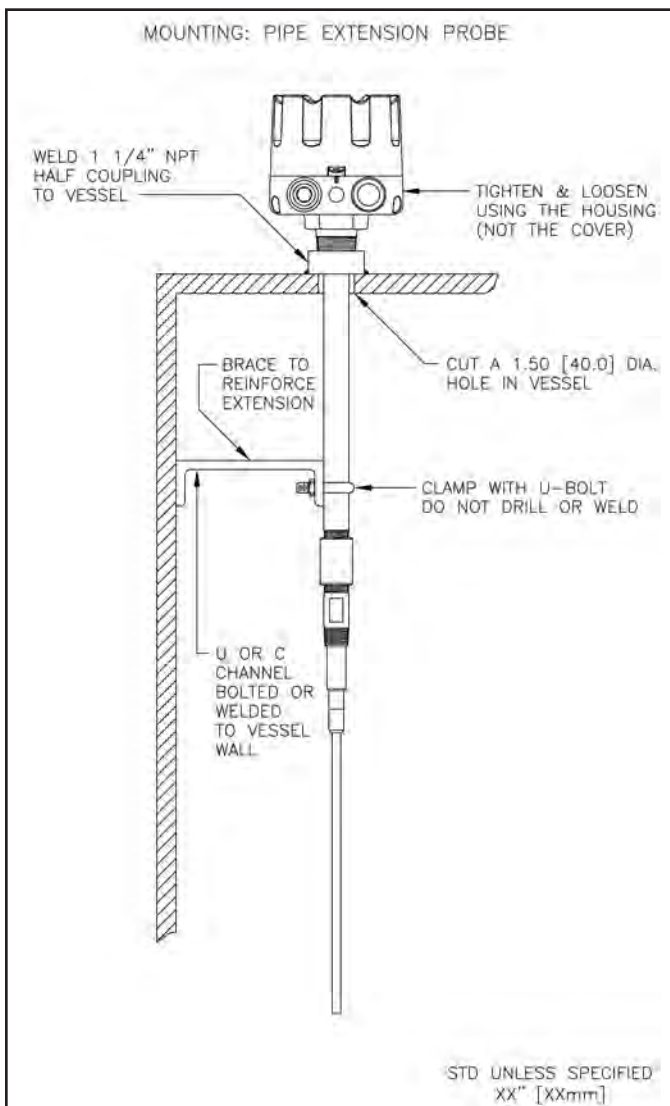

Figure 7

Remote Electronics Mounting

The split architecture configuration is used to protect the electronics from excessive heat or physical vibration.

- 1) Select a location that is within 12 feet (3.6m) wiring distance of the remote probe but where the extreme temperatures or vibration is not present.
- 2) The Remote Electronics for Ordinary Locations has no holes cut in the fiberglass box. Drill holes in enclosure insuring circuit separation between the remote probe interconnection and the mains/outputs. Remove electronics (4 backpanel screws) prior to drilling holes.
- 3) Drill a hole pattern in the structure to which the Remote Electronics will be mounted (See Mechanicals for details).
- 4) Secure the enclosure to the structure using 1/4" (6mm) screws.

ELECTRICAL INSTALLATION

Hazardous Location Precautions:

Observe the regulations listed in the National Electrical Code regarding equipment in hazardous locations. In particular, install a conduit seal fitting within 2 inches (50 mm) of the RF Capacitance sensor, ensure power is disconnected whenever the cover is removed, upon completion ensure cover is completely re-attached and terminate IS ground screw to local intrinsically safe ground. Do not substitute any electrical components as this may impair intrinsic safety and thereby compromise safety.

Factory Wiring:

The MK-2e probe wires are connected to the backside of the PCB. **DO NOT** alter this connection. Doing will likely cause improper operation of the sensor.

Permanently Connected Equipment:

 Disconnecting devices shall be included in the system installation. In installations where multiple circuits are used (i.e. independent circuits for power input and output relay), individual disconnects are required. The disconnects shall be within close proximity of the equipment, accessible to operators, and marked appropriately as the disconnect for the associated circuit. Assure the disconnect ratings are appropriately sized for the circuit protected (See Specifications).

Circuit Separation:

Two cable entry locations are provided to aid in maintaining separation of "hazardous live" (typically mains voltages such as 115VAC and 230VAC) and limited circuits (typically control voltages less than 30Vrms or 42.4VDC). However, since the MK-2e's single wiring compartment can not absolutely protect against physical contact between multiple circuits, it is required that all wiring used must have an insulation rating of 300V minimum, and a temperature rating of 80° C (176° F) minimum.

Protective Earthing:

 Each MK-2e is provided with a "protective conductor terminal" which shall be terminated to the local earth ground potential to eliminate shock hazard in the unlikely event of internal insulation breakdown. Select wire size that can carry in excess of the sum of all circuit's maximum amperage.

Power Input:

The MK-2e is designed to accept either 115VAC, 230VAC or 24VDC (factory set). Verify the intended voltage supply is compatible with the voltage configuration indicated on the electronics and the external nameplate. Connect power as shown in Figures 8 and 9. Select wire size that can deliver suitable voltage and current for the application.

⚠ The 24VDC model must be supplied by a SELV source. Observe polarity when using this VDC source.

Output Relay Contacts:

The MK-2e is equipped with one or two sets of isolated contacts (DPDT for hazardous or remote electronics, SPDT for ordinary location integral electronics) which indicates whether or not material is being detected within the vessel. This output is also influenced by the selection of the "fail-safe" switch as described in the "Calibration" section of this manual. The designations on the circuit board relate to the contact status when the material is "not" sensed and the fail-safe switch is in the "low" mode. These contacts can be connected to any type of control device, provided that ratings are observed (See Specifications). Select wire size that can deliver suitable voltage and current for the application.

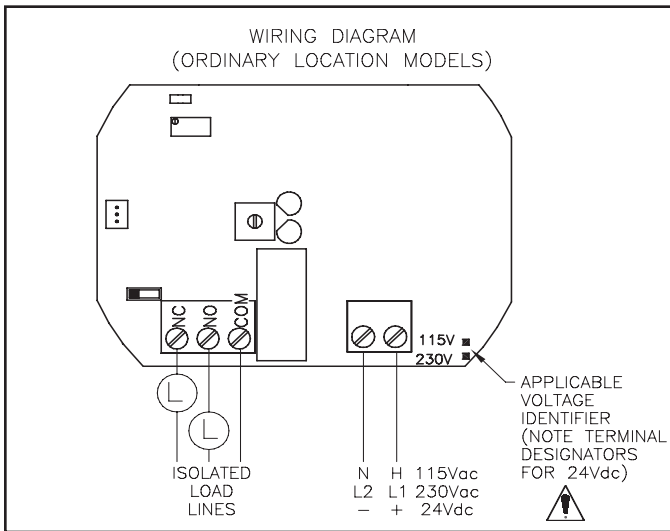

Figure 8

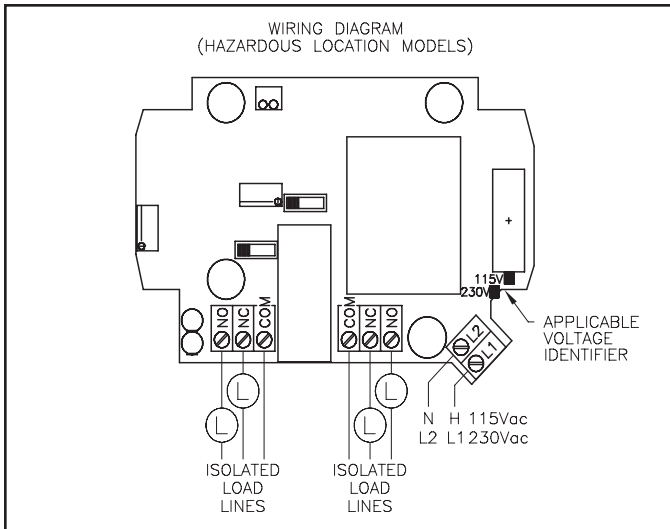

Figure 9

Split Architecture: (See Figure 10)

The interconnection of the remote probe and the remote electronics is limited in distance in order to maintain the sensing capability. Separation distances greater than the standard 12 feet (3.6 m) or use of an interconnection cable other than Monitor's should not be attempted without the approval of Monitor's Application Engineers.

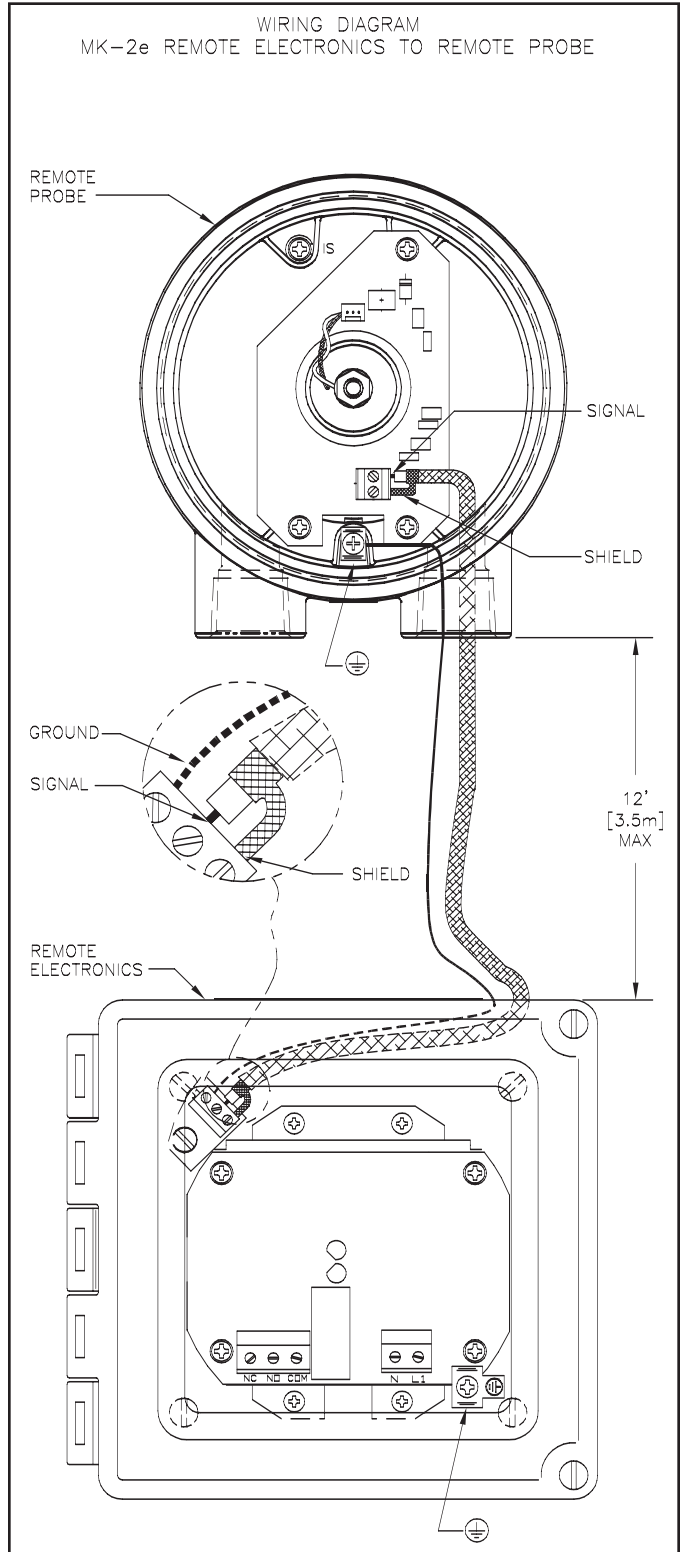

Figure 10

CALIBRATION

Sensitivity: (See Figure 11 or Figure 12)

Sensitivity is set in the field via a "Sense Adjust" 25-turn potentiometer. Hazardous location approval units also have a "Sense Select" switch (See Figure 12). The switch selects the range of capacitance expected to be seen at the probe.

High: When selected, this position permits calibration when the capacitance detected on the probe is 0-75pf. This factory setting will satisfy most applications.

Low: When selected, this position permits calibration when the capacitance detected on the probe is 70-150pf. This setting may be required for conductive applications or long cable extension configurations where initial capacitance is great. Setting can be selected in the field.

The "Sense Adjust" tunes the sensitivity of the MK-2e to the material being sensed. Rotating the adjustment in a clockwise direction will increase the sensitivity making the material easier to "detect". There are two different procedures which can be used in the calibration process. Both utilize the simple "2-Step Calibration" procedure. One procedure sets the sensitivity with the probe being exposed to the material, while the second procedure exposes the probe to free air only. Since the capacitance being measured is directly related to the material being sensed, the best results will be achieved by setting the calibration while the probe is exposed to the application material.

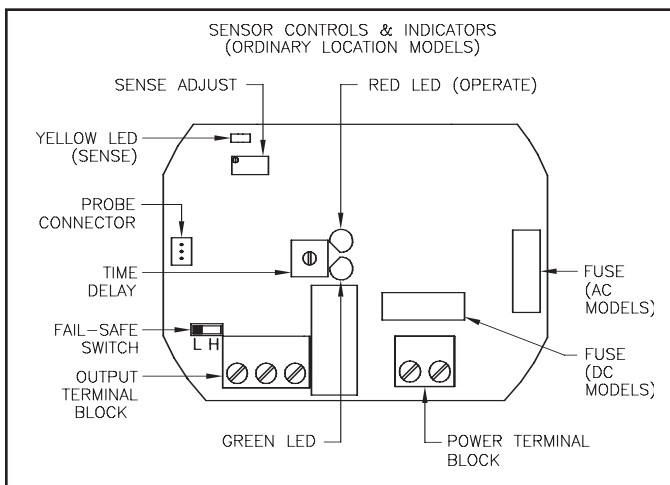

Figure 11

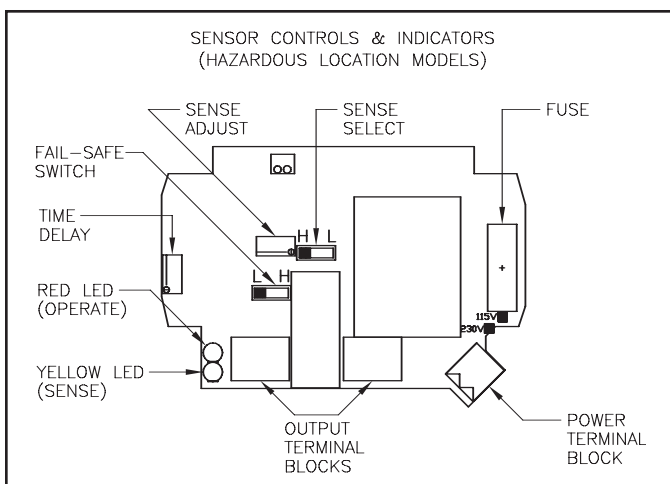

Figure 12

2-Step Calibration- probe exposed to material

- 1) While the probe is not covered with material, rotate "Sense Adjust" clockwise just until "Sense" (yellow) LED turns on.
- 2) Permit the application material to cover the probe. **While counting the number of revolutions**, rotate "Sense Adjust" counter-clockwise until the "Sense" (yellow) LED turns off. Reposition "Sense Adjust" at the half way point between the LED on and LED off settings. (e.g. After inserting the probe into the material, if it takes 2 counter-clockwise turns of "Sense Adjust" for the "Sense" (yellow) LED to turn off, then "Sense Adjust" should be repositioned 1 clockwise turn.)

2-Step Calibration- probe exposed to free air only

- 1) Rotate "Sense Adjust" clockwise just until the "Sense" (yellow) LED turns on.
- 2) Reposition "Sense Adjust" a number of turns counter-clockwise with respect to the three described sensitivities below (see Figure 13). It is desirable to reposition "Sense Adjust" in accordance to "2-Step Calibration - probe exposed to material" procedure once material can cover the probe. Materials with high dielectric constants or conductivity, require the sensitivity adjustment further counter-clockwise than those applications with low dielectric constants.

SENSITIVITY SETTING OF THE MK-2e			
SENSITIVITY DESCRIPTION	NO. OF ADJ TURNS	MATERIAL DIELECTRICS	TYPICAL APPLICATIONS
HIGH	0-1	1.5-3.0	PLASTICS, SOAP, OILS, RUBBER, CEMENT
MED	1-3	3.0-9.0	GRAINS, FERTILIZERS, FEED, SALT
LOW	> 3	> 9.0	WASTEWATER, SLURRIES, ANY WATER BASED SOLUTIONS

Figure 13

Delay:

A potentiometer is provided for setting the time delay between the time material is "sensed" (Yellow LED on) and the time the relay contact output changes (Red LED on). Hazardous location approval units have a 25-turn potentiometer and ordinary locations approval units have a 1-turn potentiometer. A clockwise rotation will increase the delay from .25 to 15 seconds. This adjustment minimizes false signals associated with temporary material shifts. The delay between the time material is "not sensed" (Yellow LED off) and the time the relay contact output changes (Red LED off) is fixed at .25 seconds.

Fail-safe: (see Figure 14)

The term fail-safe refers to the output signal condition which occurs with a loss of power to the probe. A switch permits selection of either low or high fail-safe.

High Fail-Safe: The relay will de-energize when material is sensed at high level or with power loss.

Low Fail-Safe: The relay will de-energize when material is below low level or with power loss. Note the designations on the electronics label refer to the relay contact status when no material is sensed and low fail-safe is selected (Relay is de-energized). The designations are reversed when no material is sensed and high fail-safe is selected (Relay is energized).

TROUBLESHOOTING

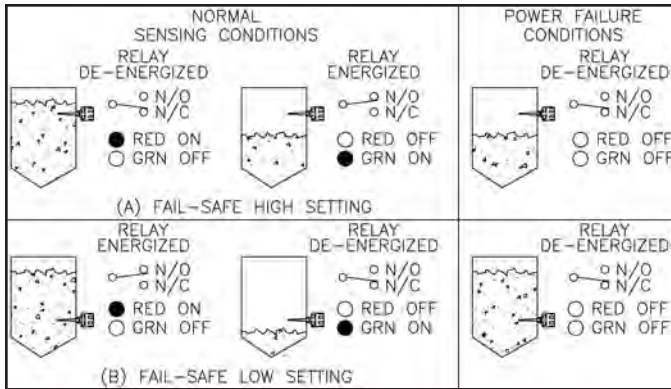

Indicators: (See Figure 15)

- 1) **Yellow LED** - Its status describes the "sensing" condition of the MK-2e. Illumination indicated that the amount of capacitance established by the "Sense Adjust" has been detected. Its status is not affected by the time delay setting of the fail-safe setting. This LED can only be seen when the cover has been removed.
- 2) **Red LED** - Its status describes the "operate/output" condition of the MK-2e. Illumination indicated the relay is in the "operate/material sensed" condition. Its state is influenced by the time delay setting but not by the fail-safe setting. On ordinary location approval units, this LED is aimed at the lens in the cover so it can be seen with the cover on or off.
- 3) **Green LED** - (Ordinary location approval units only) Its status indicates "no material sensed" condition of the MK-2e in combination with the time delay setting. If material has not been sensed for a long enough time (as set by the time delay setting), this LED will be illuminated. The red and green LEDs should never be illuminated at the same time. The green LED's state is not affected by the fail-safe setting. This LED is also aimed at the lens in the cover so that it can be seen with the cover on or off.

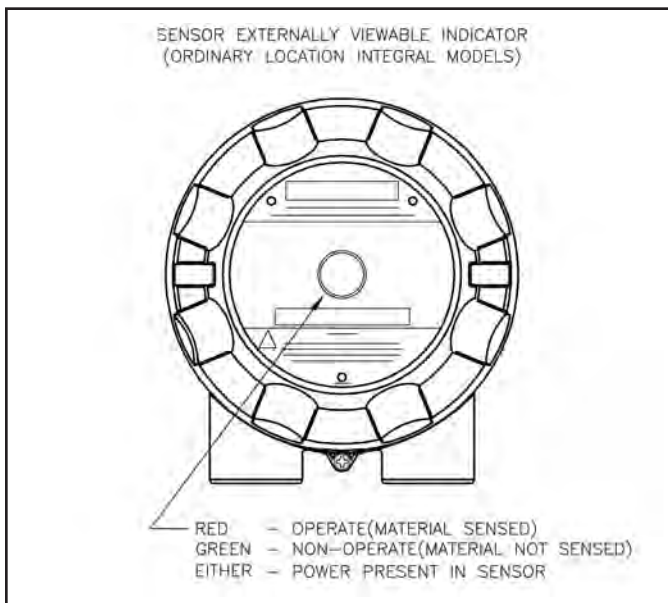

PROBLEM: Sensor will not sense material

- CAUSE/SOLUTION:**
- 1) Verify power is applied to the sensor.
 - 2) Verify "Sense Adjust." Reposition adjustment clockwise therefore making the probe more sensitive to "difficult to sense" materials.
 - 3) Verify "Sense Select" setting (hazardous location approval units only). If full clockwise rotation of "Sense Adjust" never permits sensing, reposition "Sense Select" to "HIGH" setting and recalibrate "Sense Adjust" setting.
 - 4) Verify probe coverage when sensing is expected. The sensor is not designed to be "tip sensitive." Permit significant probe coverage before expecting material sensing.
 - 5) Verify electrical continuity between sensor housing and vessel wall.
 - 6) Verify connection of the electronic module to the probe.

PROBLEM: Sensor remains in the "SENSE" mode even when material is absent

- CAUSE/SOLUTION:**
- 1) Verify the active probe is not in direct contact with any internal vessel structure. If so, reposition sensor.
 - 2) Verify "Sense Adjust" setting. Reposition adjustment counter-clockwise therefore making the probe less sensitive to "easy to sense" materials.
 - 3) Verify "Sense Select" setting (hazardous location approval units only). If full counter-clockwise rotation of "Sense Adjust" keeps sensor in "SENSE" mode, reposition "Sense Select" to "LOW" setting and recalibrate "Sense Adjust" setting.
 - 4) Verify there is not a large buildup of material between the active probe and the probe housing. See "Cleaning" in the "Maintenance" section of this bulletin.

PROBLEM: Sensor does not seem to hold its calibration

- CAUSE/SOLUTION:**
- 1) Verify that the "sense adjust" is positioned at ideal point as described in 2-Step Calibration procedure. Placing setting too close to threshold can create nuisance false signals.
 - 2) Maximize probe coverage of material being sensed. "Difficult to detect" materials (i.e. low dielectric or light materials) are more easily detected when more probe is covered. Avoid setups where "probe tip sensitivity" is required.
 - 3) Insure electrical continuity between the probe's mounting point (3/4" NPT, 1 1-4" NPT or 1-1/2" BSPT) and the bin wall. Sealant tapes (i.e. Teflon tape) can electrically isolate these regions and make sensing more difficult.
 - 4) Assess the temperature swing that the electronics sees in application. Applications with "difficult to detect" materials and that experience a wide temperature swing are the most vulnerable. Consult factory for support.

PROBLEM: Output contacts perform opposite of designations (N/O, N/C)

- CAUSE/SOLUTION:**
- 1) Designations on PCB relate to relay status when in "Fail-Safe Low" mode and when no material is sensed. If "Fail-safe High" mode is used, the designations are reversed. Swap wire terminations of N/O and N/C if necessary. Changing the fail-safe selection is not recommended.

MAINTENANCE

⚠ Fuse Replacement:

The fuse incorporated into the MK-2e PCB is not intended for operator replacement. A qualified technician can replace the applicable fuse according to the following specifications. If necessary, consult the factory for additional technical assistance or for return of the MK-2e.

115VAC

F1: 5x20mm, 0.63A Time Lag (Slo-Blo), 250VAC
 Littelfuse: #218.063
 Bussman: #GDC-63mA

230VAC

F1: 5x20mm, 0.32A Time Lag (Slo-Blo), 250VAC
 Littelfuse: #218.032
 Bussman: #GDC-32mA

24VDC

F1: 5x20mm, 0.125A Time Lag (Slo-Blo), 250VAC
 Littelfuse: #218.125
 Bussman: #GDC-125mA

Preventive Maintenance:

The MK-2e design is virtually maintenance free. In typical applications, once the sensor is properly calibrated, it will operate without any further attention. In abrasive applications, probe condition should be periodically observed. Although the probe's construction is made with high quality engineering plastics, heavy abrasion can wear away the probe's insulators. This can influence the calibration and eventually lead to sensor failure. The electronics are housed in a weatherproof enclosure. In addition the PCBs are conformal coated with a silicone-based material to further prevent electrical influence by condensation. The sensor electronics should periodically be observed for any signs of contamination caused by improper enclosure protection (i.e. insure cover is fully engaged, and that wire entries are properly sealed.)

Cleaning Requirements:

Environmental and hazardous location protection is highly dependent on the proper installation of the cover to the housing. A lubricant is applied to the housing/cover threads to enhance ability to twist-on twist-off cover. Clean and re-lubricate threads if necessary to insure trouble-free operation. Do not physically alter threads in anyway otherwise environmental or hazardous location protection could be compromised.

The driven shield feature of the MK-2e is designed to minimize the need for cleaning the probe portion of the sensor. In applications where material build-up is so excessive that electronics can not adequately compensate, probe cleaning may be necessary. If so, wipe the probe with a clean damp cloth from the housing to the probe tip.

MECHANICALS

DIMENSIONS ARE SHOWN IN INCHES WITH MILLIMETER EQUIVALENT IN BRACKETS

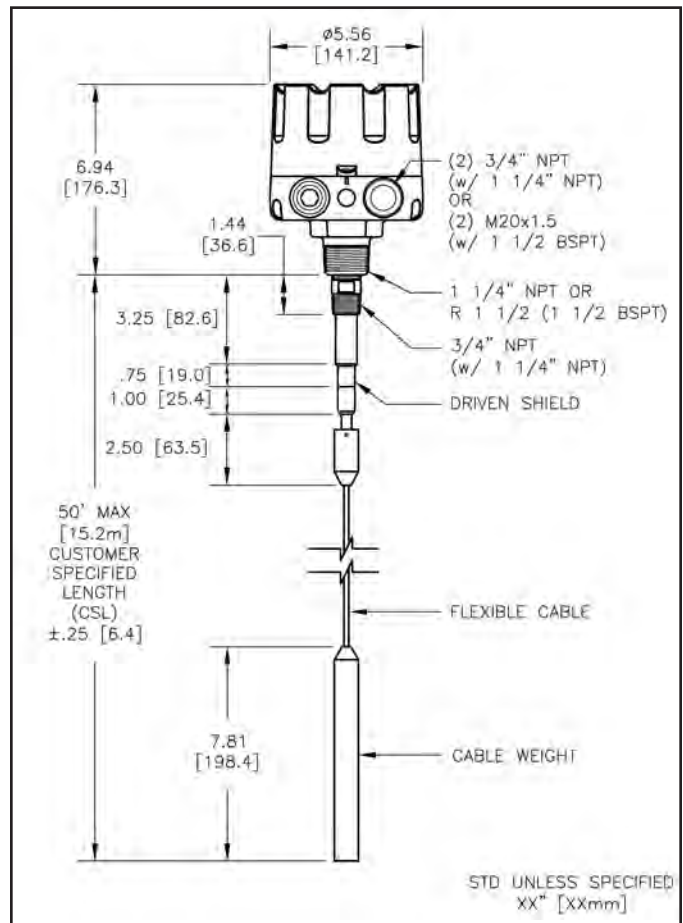
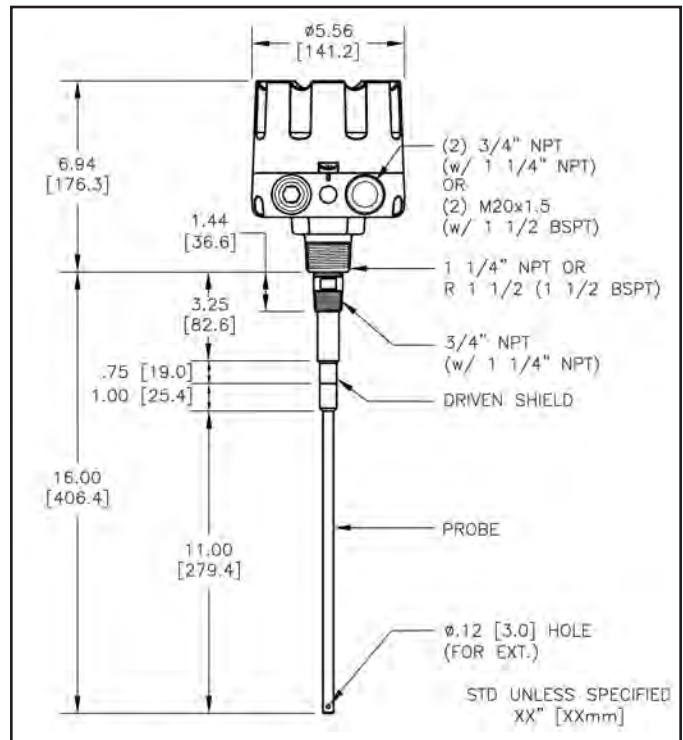

MECHANICALS

DIMENSIONS ARE SHOWN IN INCHES WITH MILLIMETER EQUIVALENT IN BRACKETS

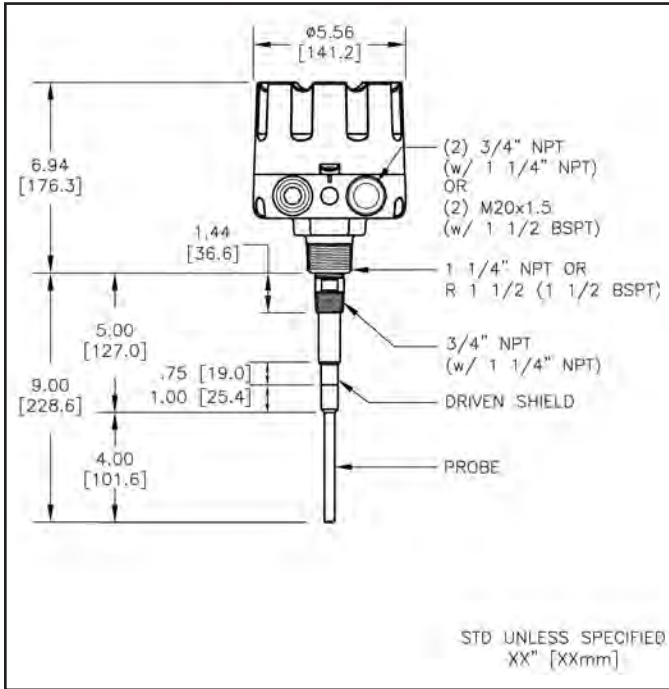

Stub Probe

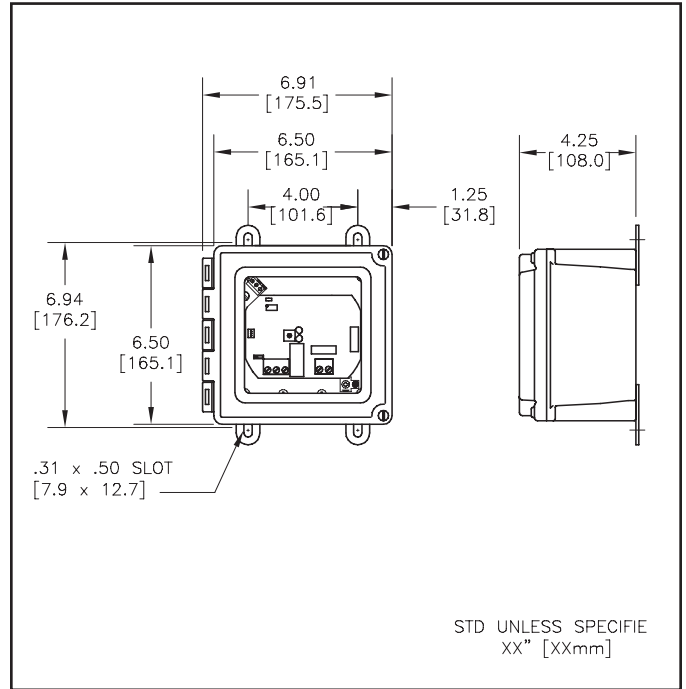

Remote Electronics

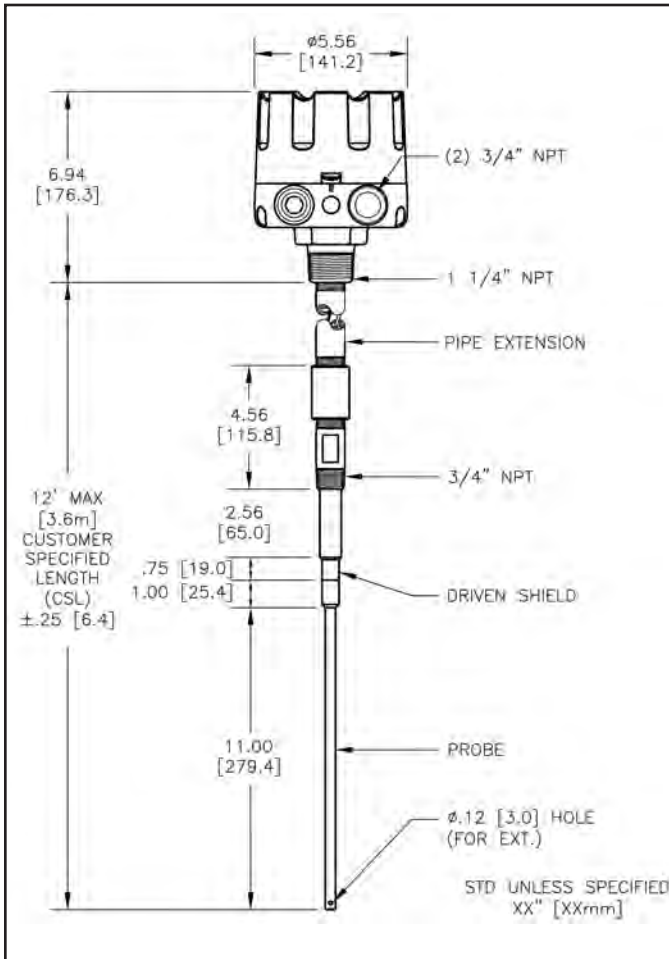

Pipe Extension Probe

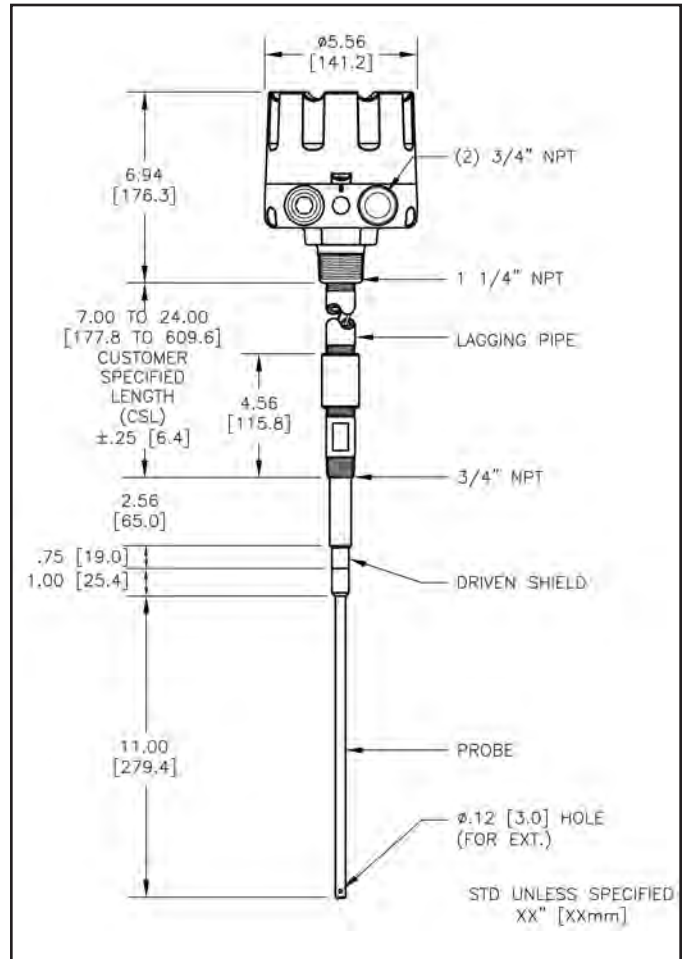

Lagged Housing Version

SAFETY

General Safety

CAUTION: It is essential that all instructions in this manual be followed to ensure proper operation of the equipment and safety of operating personnel. Use of equipment not specified herein, may impair protection provided by equipment. The use of this symbol is used throughout manual to highlight important safety issues. Please pay particular attention to these items.

Electrical Shock Caution

Certain MK-2e models are powered with HIGH VOLTAGE. No operator serviceable parts are inside. All servicing is to be performed by qualified personnel. Each MK-2e is provided with a "protective conductor terminal" which shall be terminated to earth ground potential (See Electrical Installation). This product's design complies with EN61010-1 installation category II and pollution degree 2.

Hazardous Location Caution

Certain MK-2e models can be used in Hazardous Locations (See Specifications). These models shall only be used in applications covered by stated ratings or those considered non-hazardous. Failure to comply could result in damage to personnel and property. The following must be maintained to assume safe operation:

- 1) Enclosure integrity - The dimensions of the housing, cover or probe shall not be altered.
- 2) Electrical integrity - Substitution of electrical components may impair intrinsic safety and therefore is prohibited.
- 3) Maintenance - Power to all circuits must be disconnected before conducting any investigation or maintenance.

Electromagnetic Compatibility (EMC)

The MK-2e was tested and found to comply with the standards listed below. The MK-2e should not be used in residential or commercial environments. Compliance to EMC standards was demonstrated by means of a test setup using the following installation methods.

- 1) MK-2e enclosure was connected to earth ground (protective earth).
- 2) No specific wiring convention was used to supply power or to retrieve output signal from the MK-2e.

EMC Emissions:

Meets	EN 61326-1	Electrical Equipment for Control Use, EMC
	EN 55011	Radiated and conducted emissions (Class A- industrial)
	EN 61000-3	Fluctuations/Flicker

Meets	FCC Part 15B: CISPR 11	RF Devices, Unintentional Radiators Radiated and conducted emissions (Class A- industrial)
-------	------------------------	--------------------------------------------------------------------------------------------

EMC Immunity:

Meets	EN 61326-1	Electrical Equipment for Control Use, EMC
	IEC 1000-4-2	Electrostatic discharge (industrial)
	IEC 1000-4-3	RF radiated EM fields (industrial)
	IEC 1000-4-4	Electrical fast transients (industrial)
	IEC 1000-4-5	Electrical surges (industrial)
	IEC 1000-4-6	RF conducted EM energy (industrial)
	IEC 1000-4-8	Power frequency magnetic fields (industrial)
	IEC 1000-4-11	Source voltage deviation

SPECIFICATIONS

Power:	115VAC (±15%); 2.5VA: 50/60Hz / 230VAC (±15%); 2.5VA; 50/60Hz / 24VDC (±15%); 3W (N/A on Remote Elec or Haz Loc Approval)
Altitude:	6562 ft (2000 m) max
Installation Category:	II
Pollution Degree:	4 (Reduced to 2 by enclosure) Suitable for indoor/outdoor use
Ambient Op Temp:	-40° F (-40° C) to +150° F (+65° C)
*Internal Bin Temp:	To +176° F (+80° C) w/alum. mount (<104° F (40° C) ambient) To +400° F (+204° C) w/SS mount (<122° F (50° C) ambient)
Output Relay:	SPDT, 5A @ 250VAC, 30VDC maximum
External Indicators:	Red and green LEDs indicating power and operating mode (Ordinary location units only)
Sensitivity:	Multi-turn potentiometer adjustment 0.5pf to 150 pf
Stability:	±0.015pf per degree F (±0.027pf per degree C) @ 0.5pf setting
Time Delay:	0.25 to 15 sec delay-to-activate, adjustable 0.25 sec delay-to-deactivate, fixed
Fail-Safe:	Switch selectable - HI/LO
Build-up Immunity:	Protected via driven shield to 150 ohm load
Enclosure:	Cast alum screw-on cover, beige polyester pwdr coat, NEMA 4, IP66
Conduit Connection:	Two (2) 3/4" NPT connections (M20 cable glands provided when 1-1/2" BSPT process connection is specified)
**Approvals:	CSA _{US} CSA _C : Ordinary Locations, CE Mark(Ordinary location only) CSA _{US} CSA _C : Class I Groups C,D, Exp. Proof & Intrinsically Safe CSA _{US} CSA _C : Class II Group G, Dust Ignition Proof & Intrinsically Safe
Standard/Food Grade Probe	
Mounting:	1-1/4" NPT alum, R 1-1/2 (BSPT 1-1/2) (MK-2e only), or combo 3/4" NPT 316SS and 1-1/4" NPT alum
Probe Material:	3/8in(9.5mm) dia. 316SS probe & guard, Ryton® & Nylon insulators
Probe Length:	16in(406mm) from alum mounting
Temp (Probe Only):	Ryton® +450° F (+232° C) max; Nylon +300° F (+148° C) max
Pressure:	50 psi(3.5 bar) max (alum connection);150 psi(10 bar) max (3/4" NPT SS)
Stub Probe	
Mounting:	1-1/4" NPT alum, R 1-1/2 (BSPT 1-1/2) (MK-2e only), or combo 3/4" NPT 316SS and 1-1/4" NPT alum
Probe Material:	3/8in(9.5mm) dia. 316SS probe & guard, Ryton® & Nylon insulators
Probe Length:	Cut to customer specification; application dependent
Temp (Probe Only):	Ryton® +450° F (+232° C) max; Nylon +300° F (+148° C) max
Pressure:	50 psi(3.5 bar) max (aluminum); 150 psi(10 bar) max (3/4 NPT SS)
Cable Extension Probe	
Mounting:	1-1/4" NPT alum, R 1-1/2 (BSPT 1-1/2) (MK-2e only), or combo 3/4" NPT 316SS and 1-1/4" NPT alum
Probe Material:	1/8in(3.2mm) diameter 316 SS Teflon® jkt'd cable, Nylon insulator
Cable Length:	Customer specified up to 50 ft (15 m) overall insertion from alum mtg
Temp (Probe Only):	+300° F (+148° C) max
Pressure:	50 psi(3.5 bar) max (1-1/4 NPT alum); 150 psi(10 bar) max (3/4 NPT SS)
Pipe Extension Probe	
Mounting:	1-1/4" NPT alum
Lag Material:	Galvanized or 316SS
Pipe Ext Length:	Customer specified up to 144in (3.6m) overall insertion
Interface To:	Standard or Food Grade (See applicable specs)
Lagged Housing Version	
Mounting:	3/4" NPT 316SS
Lag Material:	Galvanized or 316SS
Lag Length:	Customer specified from 7 to 24 in (178 to 610 mm)
Interface To:	Standard Probe only (See applicable specs)
Split Architecture	
Elec. Enclosure:	Fiberglass enclosure (OL)
Cable:	12 ft (3.6m), 22 awg co-ax / 18 awg wire
Max Bin Temp:	Ryton® probe: 450° F (+232° C); Nylon: 300° F (+148° C)

*Influenced by mounting, material thermal conductivity and ambient temperature.

**Hazardous location approvals on units with Pipe Extension or Lagged Probes with integral electronics/probe are CSA_{US/C} Class II Group G (SS version ONLY). Hazardous location approvals are not available on the galvanized version).

Ryton® - Trademark of Phillips Chemical Co. Teflon® - Trademark of DuPont Chemical Co.

WARRANTY

Monitor Technologies LLC warrants each TrueCap® RF capacitance sensor it manufactures to be free from defects in material and workmanship under normal use and service for two (2) years from the date of purchase. The purchaser must notify Monitor of any defects within the warranty period, return the product intact, and prepay transportation charges. The obligation of Monitor Technologies LLC under this warranty is limited to repair or replacement at its factory. This warranty does not apply to any product which is repaired or altered outside of Monitor Technologies' factory, or which has been subject to misuse, negligence, accident, incorrect wiring by others, or improper installation.