

Quality Screw Conveyor Unit Modules

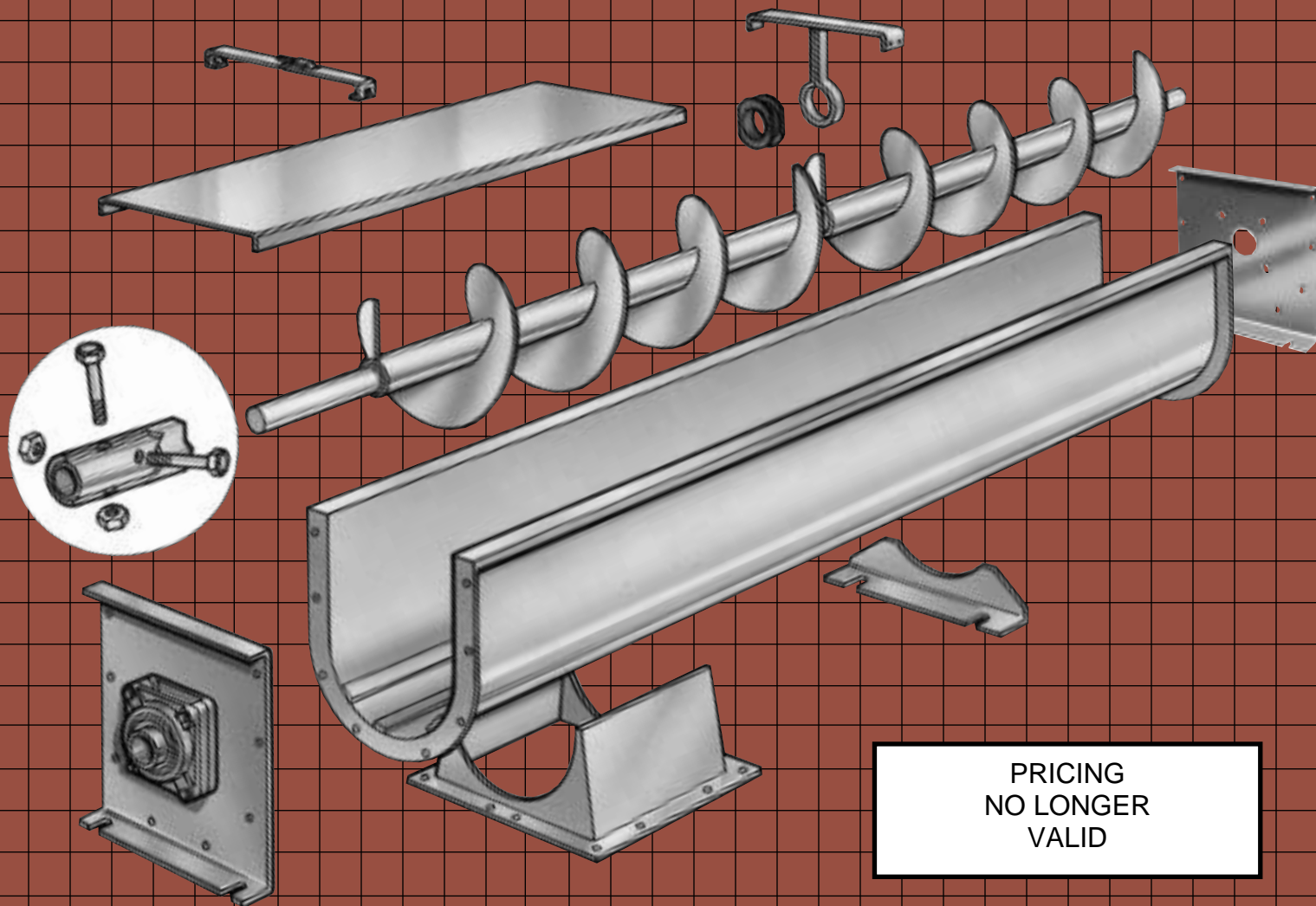

PRICING
NO LONGER
VALID



THE EXPERIENCE
TO HANDLE IT RIGHT!®

Screw Conveyor Corporation

SIMPLIFY PURCHASING SCREW CONVEYORS: BUY UNIT MODULES

- Three Grades of CEMA Construction for Screw Diameters 6, 9, 12, 14 & 16.
 - Normal Duty — Usually for Non-Abrasive materials with up to 45% trough loading.
 - Heavy Duty — For Abrasive or Non-Abrasive material with up to 30% trough loading.
 - Extra Heavy Duty — Built for applications where special metals or coatings are not required.
- Package Pricing for Timely Customer Response
- Three Easy to Order Size Codes for Each Service Duty

Standard Base	10' Long for 6" & 9"	12' Long for all others
Std Unit Extension	10' Long for 6" & 9"	12' Long for all others
Unit Half Extension	5' Long for 6" & 9"	6' Long for all others
- Basic Unit modules eliminates bothersome component pricing accumulation.
- Focuses customers on buying and employees on selling three grades of service.

KEY UNIT MODULE SPECIFICATIONS BASIC COMPONENTS

Standard Base	Standard Extension	Half Extension
1 Full Pitch Screw	1 Full Pitch Screw	1 Full Pitch Screw, Half Length
1 Trough	1 Trough	1 Trough, Half Length
1 Cover W/3 Barron Cover Clamps and Screw Clamps for Single Flange	1 Cover W/2 Barron Cover Clamps and Screw Clamps for Single Flange	1 Cover W/2 Barron Cover Clamps and Screw Clamps for Single Flange, Half Length
1 Inlet and Discharge Loose	1 Coupling Shaft	1 Coupling Shaft
1 Tail Shaft	1 Hanger Frame & Bearing	1 Hanger Frame & Bearing
1 Trough End for Screw Conveyor Drive	1 Support Foot	1 Support Foot
1 Trough End, Anti-friction Flange Bearing & Waste Pack Seal		

- All components are of CEMA standard construction and tolerances.
- Screws and inside troughs are unpainted.
- Full Pitch screws intended for control feed, and provided with no bare pipe for discharge.
- Nylon Bearings can be substituted for wood, use the SCC Part Number listed plus an "A".
- All components of mild steel except for hanger bearings.
- Units shipped ready to assemble with bolts.
- Additional component parts can be ordered per SCC catalog 787 and Price list SC-01.
- All other unit components cannot be substituted, exchanged, or returned.

***Purchaser assumes all responsibility for sizing and suitability of the unit for any application.**

6"

SCREW CONVEYOR UNIT MODULES

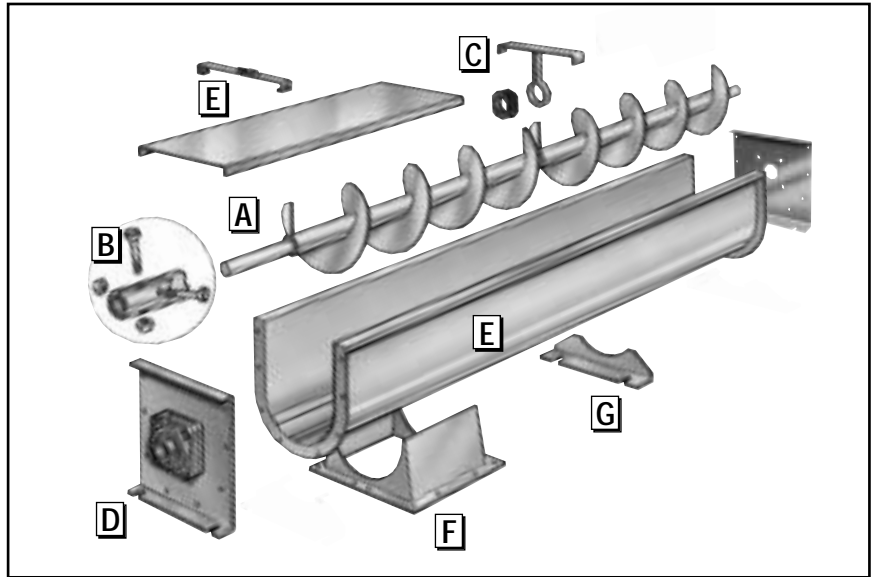

Module Components	Normal Duty	Heavy Duty	Extra Heavy Duty
A Conveyor Screw	6H304	6H312	6S324
B Coupling Shafts Tem-U-Lac Bolts	Standard 1 1/2 "	Standard 1 1/2 "	Hardened 1 1/2 "
	Standard Grade 5	Standard Grade 5	Standard Grade 5
C Hangers Bearings	226	226	226
	Wood	Wood	Hard Iron
D Trough Ends	*	*	*
E Covers Screw Clamps Troughs	Barron	Barron	Flanged and Gasketed
	Not Required	Not Required	10 Provided
	Double Flange 14 GA.	Double Flange 10 GA.	Single Flange 3/16"
F Inlet (Loose) Discharge (Loose)	12 GA.	12 GA.	12 GA.
	12 GA.	12 GA.	10 GA.
G Support Feet	Standard	Standard	Standard

* One End For Screw Conveyor Drive and Opposite End With Anti-Friction Bearing and Waste Pack Seal, and Assembly Bolts

Length	Normal Duty			Heavy Duty			Extra Heavy Duty		
	Part No.	Size Code	List Price	Part No.	Size Code	List Price	Part No.	Size Code	List Price
Standard Base Unit	3550019	S06H304DSB5	\$ 882	3550167	S06H312DSB3	\$ 989	3550084	S06S324SSB2	\$1,327
Standard Unit Extension	3550043	S06H304DSE5	\$ 576	3550068	S06H312DSE3	\$ 683	3550092	S06S324SSE2	\$1,044
Unit Half Extension	3550050	S06H304DHE5	\$ 522	3550076	S06H312DHE3	\$ 598	3550100	S06S324SHE2	\$ 882

DO NOT OPERATE LOWER THAN RPM'S LISTED BELOW.

Minimum RPM'S for Each Shaft Size															
Horsepower	.5	.75	1	2	3	5	7 1/2	10	15	20	25	30	40	50	60
Shaft Size 1 1/2"	11	16	21	41	62	103	154								
2"	5	7	9	17	25	42	63	83	125	166					
2 7/16"	3	4	5	9	13	21	32	42	63	84	105	126	168		
3"	2	2	3	5	7	12	17	23	34	45	56	67	89	112	134
3 7/16"	1	2	2	3	5	8	12	15	23	30	38	45	60	75	89

9"

SCREW CONVEYOR UNIT MODULES

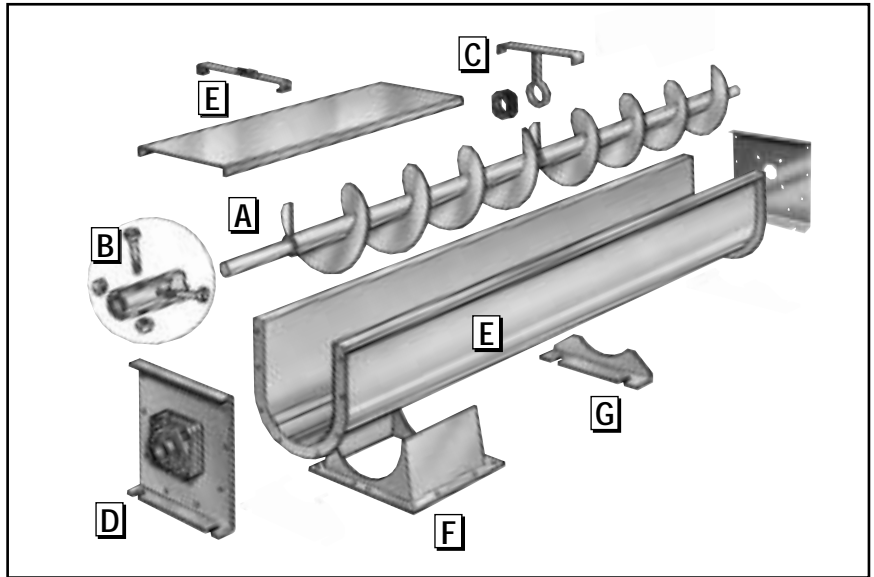

Module Components	Normal Duty	Heavy Duty	Extra Heavy Duty
A Conveyor Screw	9H306	9H312	9S424
B Coupling Shafts Tem-U-Lac Bolts	Standard 1 1/2"	Standard 1 1/2"	Hardened 2"
	Standard Grade 5	Standard Grade 5	Standard Grade 5
C Hangers Bearings	226	226	226
	Wood	Wood	Hard Iron
D Trough Ends	*	*	*
E Covers Screw Clamps Troughs	Barron	Barron	Flanged and Gasketed
	Not Required	Not Required	10 Provided
	Double Flange 14 GA.	Double Flange 10 GA.	Single Flange 3/16"
F Inlet (Loose) Discharge (Loose)	10 GA.	10 GA.	10 GA.
	10 GA.	10 GA.	10 GA.
G Support Feet	Standard	Standard	Standard

* One End For Screw Conveyor Drive and Opposite End With Anti-Friction Bearing and Waste Pack Seal, and Assembly Bolts

Length	Normal Duty			Heavy Duty			Extra Heavy Duty		
	Part No.	Size Code	List Price	Part No.	Size Code	List Price	Part No.	Size Code	List Price
Standard Base Unit	3550423	S09H306DSB5	\$ 965	3550514	S09H312DSB3	\$1,102	3550696	S09S424SSB2	\$1,604
Standard Unit Extension	3550118	S09H306DSE5	\$ 622	3550134	S09H312DSE3	\$ 759	3550191	S09S424SSE2	\$1,245
Unit Half Extension	3550126	S09H306DHE5	\$ 581	3550142	S09H312DHE3	\$ 688	3550209	S09S424SHE2	\$ 974

DO NOT OPERATE LOWER THAN RPM'S LISTED BELOW.

Minimum RPM'S for Each Shaft Size															
Horsepower	.5	.75	1	2	3	5	7 1/2	10	15	20	25	30	40	50	60
Shaft Size 1 1/2"	11	16	21	41	62	103	154								
2"	5	7	9	17	25	42	63	83	125	166					
2 7/16"	3	4	5	9	13	21	32	42	63	84	105	126	168		
3"	2	2	3	5	7	12	17	23	34	45	56	67	89	112	134
3 7/16"	1	2	2	3	5	8	12	15	23	30	38	45	60	75	89

12"

SCREW CONVEYOR UNIT MODULES

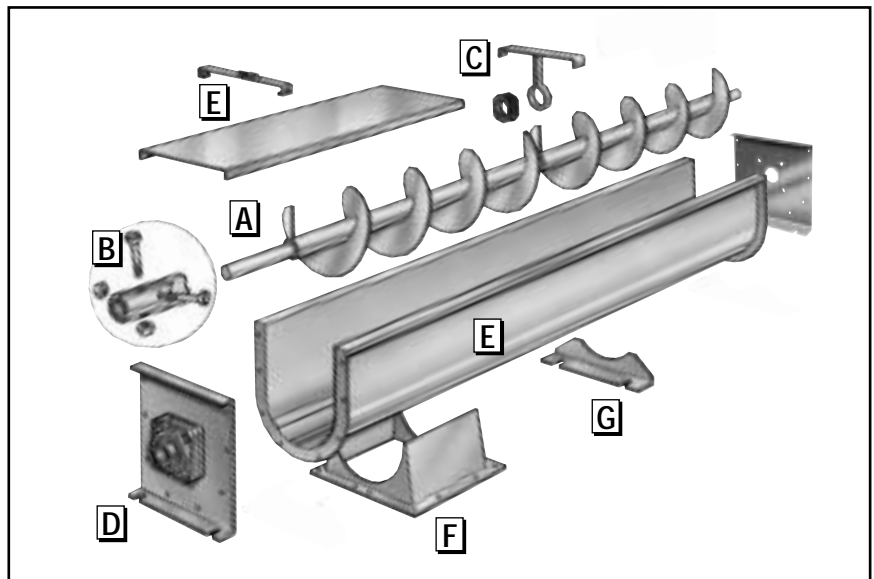

Module Components	Normal Duty	Heavy Duty	Extra Heavy Duty
A Conveyor Screw	12H408	12H512	12S624
B Coupling Shafts Tem-U-Lac Bolts	Standard 2"	Standard 2 ⁷ / ₁₆ "	Hardened 3"
	Standard Grade 5	Standard Grade 5	Standard Grade 5
C Hangers Bearings	226	226	226
	Wood	Wood	Hard Iron
D Trough Ends	*	*	*
E Covers Screw Clamps Troughs	Barron	Barron	Flanged and Gasketed
	Not Required	Not Required	10 Provided
	Double Flange 12 GA.	Double Flange 10 GA.	Single Flange 3/16"
F Inlet (Loose) Discharge (Loose)	12 GA.	3/16"	3/16"
	12 GA.	3/16"	3/16"
G Support Feet	Standard	Standard	Standard

* One End For Screw Conveyor Drive and Opposite End With Anti-Friction Bearing and Waste Pack Seal, and Assembly Bolts

Length	Normal Duty			Heavy Duty			Extra Heavy Duty		
	Part No.	Size Code	List Price	Part No.	Size Code	List Price	Part No.	Size Code	List Price
Standard Base Unit	3550878	S12H408DSB4	\$1,425	3550158	S12H512DSB3	\$1,749	3551231	S12S624SSB2	\$2,397
Standard Unit Extension	3550217	S12H408DSE4	\$ 970	3550235	S12H512DSE3	\$1,236	3550258	S12S624SSE2	\$1,812
Unit Half Extension	3550225	S12H408DHE4	\$ 868	3550241	S12H512DHE3	\$1,092	3550266	S12S624SHE2	\$1,519

DO NOT OPERATE LOWER THAN RPM'S LISTED BELOW.

Minimum RPM'S for Each Shaft Size															
Horsepower	.5	.75	1	2	3	5	7 ¹ / ₂	10	15	20	25	30	40	50	60
Shaft Size 1 ¹ / ₂ "	11	16	21	41	62	103	154								
2"	5	7	9	17	25	42	63	83	125	166					
2 ⁷ / ₁₆ "	3	4	5	9	13	21	32	42	63	84	105	126	168		
3"	2	2	3	5	7	12	17	23	34	45	56	67	89	112	134
3 ⁷ / ₁₆ "	1	2	2	3	5	8	12	15	23	30	38	45	60	75	89

14"

SCREW CONVEYOR UNIT MODULES

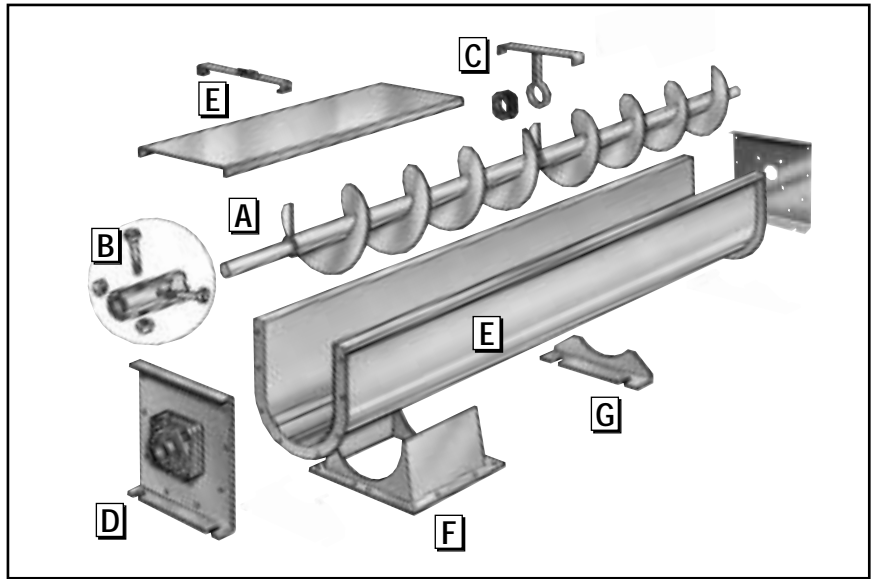

Module Components	Normal Duty	Heavy Duty	Extra Heavy Duty
A Conveyor Screw	14H508	14H614	14S624
B Coupling Shafts Tem-U-Lac Bolts	Standard 2 ⁷ / ₁₆ "	Standard 3"	Hardened 3"
	Standard Grade 5	Standard Grade 5	Standard Grade 5
C Hangers Bearings	226	226	226
	Wood	Wood	Hard Iron
D Trough Ends	*	*	*
E Covers Screw Clamps Troughs	Barron	Barron	Flanged and Gasketed
	Not Required	Not Required	10 Provided
	Double Flange 12 GA.	Double Flange 10 GA.	Single Flange 3/16"
F Inlet (Loose) Discharge (Loose)	12 GA.	3/16"	3/16"
	12 GA.	3/16"	3/16"
G Support Feet	Standard	Standard	Standard

* One End For Screw Conveyor Drive and Opposite End With Anti-Friction Bearing and Waste Pack Seal, and Assembly Bolts

Length	Normal Duty			Heavy Duty			Extra Heavy Duty		
	Part No.	Size Code	List Price	Part No.	Size Code	List Price	Part No.	Size Code	List Price
Standard Base Unit	3550274	S14H508DSB4	\$1,639	3553666	S14H614DSB3	\$2,131	3551751	S14S624SSB2	\$2,628
Standard Unit Extension	3550324	S14H508DSE4	\$1,118	3553682	S14H614DSE3	\$1,442	3551892	S14S624SSE2	\$1,986
Unit Half Extension	3550332	S14H508DHE4	\$ 989	3553674	S14H614DHE3	\$1,244	3551884	S14S624SHE2	\$1,643

DO NOT OPERATE LOWER THAN RPM'S LISTED BELOW.

Horsepower	Minimum RPM'S for Each Shaft Size															
	.5	.75	1	2	3	5	7 ¹ / ₂	10	15	20	25	30	40	50	60	
Shaft Size 1 ¹ / ₂ "	11	16	21	41	62	103	154									
2"	5	7	9	17	25	42	63	83	125	166						
2 ⁷ / ₁₆ "	3	4	5	9	13	21	32	42	63	84	105	126	168			
3"	2	2	3	5	7	12	17	23	34	45	56	67	89	112	134	
3 ⁷ / ₁₆ "	1	2	2	3	5	8	12	15	23	30	38	45	60	75	89	

16"

SCREW CONVEYOR UNIT MODULES

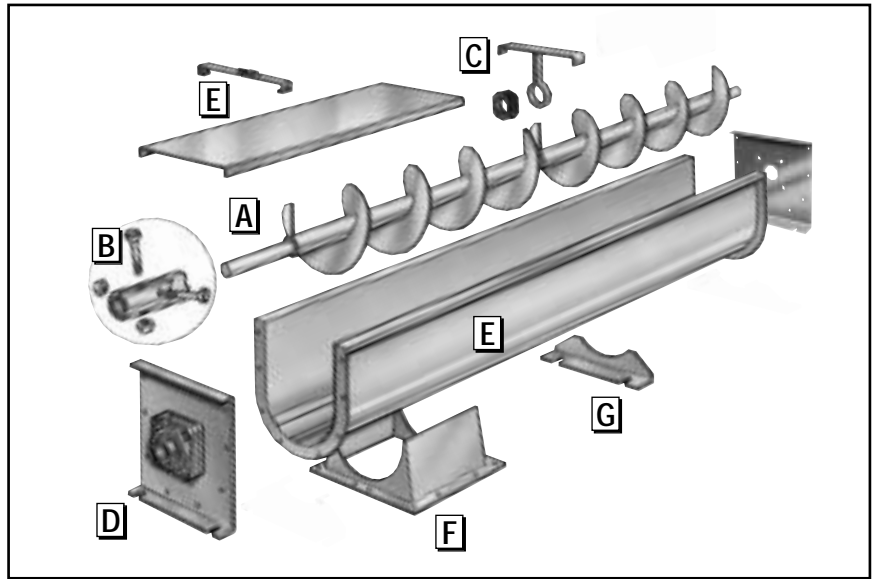

Module Components	Normal Duty	Heavy Duty	Extra Heavy Duty
A Conveyor Screw	16H610	16H614	16S624
B Coupling Shafts Tem-U-Lac Bolts	Standard 3"	Standard 3"	Hardened 3"
	Standard Grade 5	Standard Grade 5	Standard Grade 5
C Hangers Bearings	226	226	226
	Wood	Wood	Hard Iron
D Trough Ends	*	*	*
E Covers Screw Clamps Troughs	Barron	Barron	Flanged and Gasketed
	Not Required	Not Required	10 Provided
	Double Flange 12 GA.	Double Flange 10 GA.	Single Flange 3/16"
F Inlet (Loose) Discharge (Loose)	10 GA.	3/16"	3/16"
	10 GA.	3/16"	3/16"
G Support Feet	Standard	Standard	Standard

* One End For Screw Conveyor Drive and Opposite End With Anti-Friction Bearing and Waste Pack Seal, and Assembly Bolts

Length	Normal Duty			Heavy Duty			Extra Heavy Duty		
	Part No.	Size Code	List Price	Part No.	Size Code	List Price	Part No.	Size Code	List Price
Standard Base Unit	3551918	S16H610DSB4	\$2,065	3552072	S16H614DSB3	\$2,508	3552239	S16S624SSB2	\$2,851
Standard Unit Extension	3552056	S16H610DSE4	\$1,348	3552213	S16H614DSE3	\$1,745	3552379	S16S624SSE2	\$2,135
Unit Half Extension	3552049	S16H610DHE4	\$1,190	3552205	S16H614DHE3	\$1,462	3552361	S16S624SHE2	\$1,719

DO NOT OPERATE LOWER THAN RPM'S LISTED BELOW.

Minimum RPM'S for Each Shaft Size															
Horsepower	.5	.75	1	2	3	5	7 1/2	10	15	20	25	30	40	50	60
Shaft Size 1 1/2"	11	16	21	41	62	103	154								
2"	5	7	9	17	25	42	63	83	125	166					
2 7/16"	3	4	5	9	13	21	32	42	63	84	105	126	168		
3"	2	2	3	5	7	12	17	23	34	45	56	67	89	112	134
3 7/16"	1	2	2	3	5	8	12	15	23	30	38	45	60	75	89

SCREW CONVEYOR SAFETY PRACTICES



TO AVOID UNSAFE OR HAZARDOUS CONDITIONS, THE FOLLOWING MINIMUM PROVISIONS MUST BE STRICTLY OBSERVED.

- (A) **SCREW CONVEYORS SHALL NEVER BE OPERATED UNLESS THE CONVEYOR HOUSING COMPLETELY ENCLOSES THE CONVEYOR MOVING ELEMENTS.** All necessary housings, covers, safety guards, railings, gratings and power transmission guards must be in place. If the conveyor is to be opened for inspection, cleaning or observation, the motor driving the conveyor is to be locked out electrically in such a manner that it cannot be started by anyone, however remote from the area unless the conveyor housing has been closed and all guards are in place. **THE HOUSINGS, COVERS AND GUARDS ARE NECESSARY TO PREVENT ANYONE FROM ENTERING, REACHING, OR FALLING INTO THE MACHINERY, WHICH MAY RESULT IN SERIOUS PERSONAL INJURY.**
 - (B) If the conveyor must have an open housing as a condition of its use, the entire open conveyor is then to be guarded by a railing, fence or rugged safety grating.
 - (C) Feed openings for shovel, front end loader or other mechanical equipment shall be constructed in such a way that the conveyor is covered by a rugged grating. If the nature of the material is such that a grating can't be used, then the exposed section of the conveyor is to be guarded by a railing and there shall be warning signs posted.
- DO NOT PLACE HANDS OR FEET IN ANY CONVEYOR OPENING, TO AVOID BEING CAUGHT BETWEEN THE ROTATING CONVEYOR SCREW AND THE CONVEYOR HOUSING.**
- DO NOT WALK ON CONVEYOR COVERS OR GRATINGS OR POWER TRANSMISSION GUARDS, TO AVOID FALLING INTO OR AGAINST THE ROTATING CONVEYOR SCREW.**
- DO NOT** poke or prod material in the conveyor with a bar or stick, to avoid being struck by the bar or stick.
- DO NOT** overload conveyor or use it for anything but its intended use.
- DO practice good housekeeping

A copy of Screw Conveyor Safety and Service Instructions are shipped as part of every order.

EXPERIENCE IN MOTION

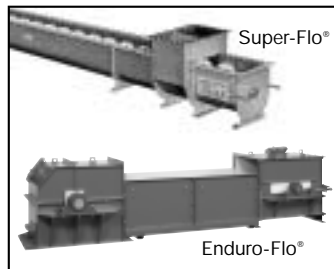
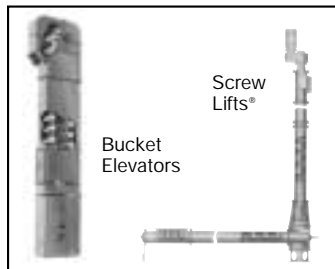
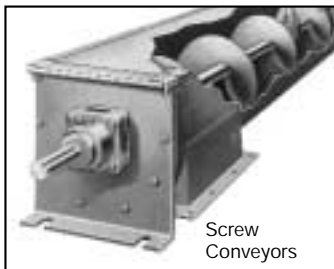

For Over 70 Years We Have Been A Dependable Source For Performance Proven Industrial Bulk Material Handling Equipment. Put Our Experience to Work for You.



Screw Conveyor Corporation

700 HOFFMAN STREET, HAMMOND, INDIANA 46327-1894 PHONE 219-931-1450 FAX: 800-805-6527 WEB ADDRESS: www.screwconveyor.com
Winona, MS 662-283-3142 Visalia, CA 559-651-2131 Chanute, KS 620-431-0440 Guadalajara, Jal. Mexico (333) 645-7110
FAX: 800-213-3084 FAX: 800-651-2135 FAX: 800-213-3086 FAX: (333) 663-2369