

# Series B/HDB Belt Conveyor OPTIONS & INSTALLATIONS

# Series B/HDB Belt CONVEYORS

## BAG TURNER

The Bag Turner option is placed between two conveyors. The bags move along the first conveyor, and are tipped on their side, and rotated by the shorter conveyor on the Bag Turner. The bags are then properly positioned to move onto additional conveyor systems. (Photo at right)



## BAG FLATTENER

The Rapat Bag Flattener option consists of a smaller powered conveyor mounted to the top of a conveyor. As bagged materials pass between the two moving belts, the material is distributed evenly within the bag, allowing uniform palletizing, stacking and easier shipping.

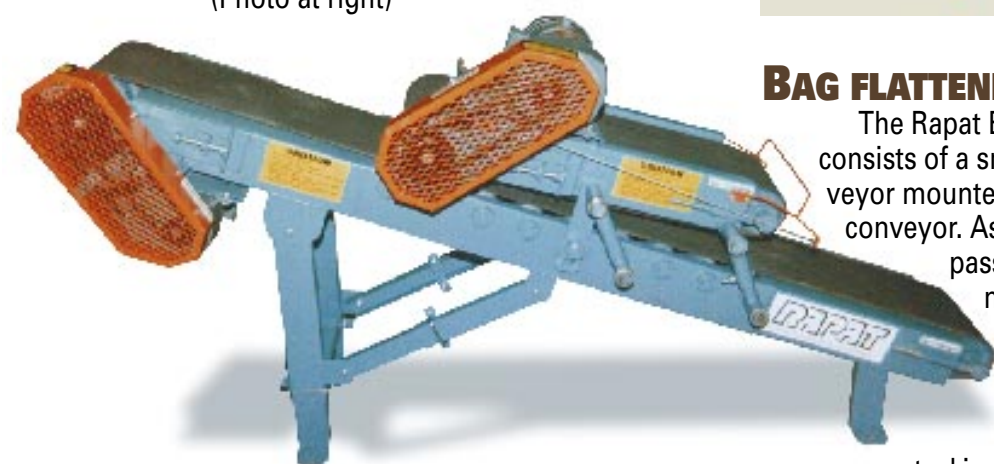

## FOOT OPERATED SWITCH

Allows operator to control conveyor start/stop while having hands free for other bagging operations.



## BAG KICKER

For applications that require the bag to be routed bottom first onto another conveyor system.

The Rapat Bag Kicker option is operated by a pneumatic cylinder, which pushes the bag from a vertical position (right after the filling and sewing operation) to a horizontal position for easier handling.

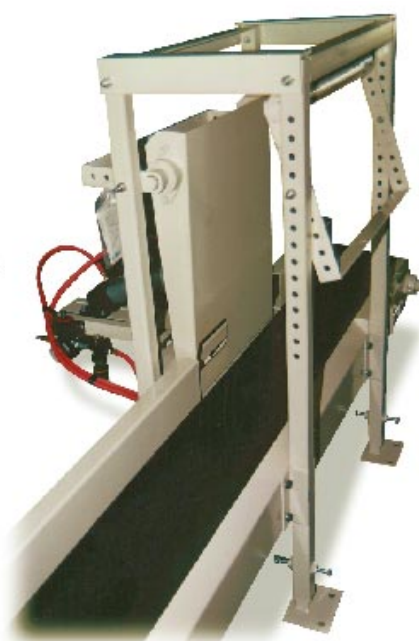

RAPAT SPECIALIZES  
IN THE CUSTOM DESIGN  
OF BELT CONVEYORS  
FOR ALL INDUSTRIES.



# Series B/HDB Belt Conveyor FEATURES

## MAKE YOUR BAG HANDLING OPERATIONS RUN SMOOTHLY

Whether you operate a one-person shop or a multi-line facility, Rapat's full line of bagging conveyors are here to assist you in running an efficient operation.

Rapat's Series B Conveyors may be used alone or in custom configurations to convey packaged product throughout your facility.

## DEPENDABLE CONVEYORS FOR ANY TASK

The Rapat Series B Conveyor line includes reliable conveyors; the Series B and HDB.

Each conveyor may be used horizontally in conjunction with sewing machines and heat sealers, or on an incline to manual or automatic palletizing systems.

## OPTIONS MAKE CUSTOM CONFIGURATIONS EASY

Few operations have the luxury of vast expanses of space for their bagging operations. Therefore, we can kick, flatten or turn your bag to fit your space allowances. Contact our system designers today to get the latest information on conveyors to fit your exact needs.

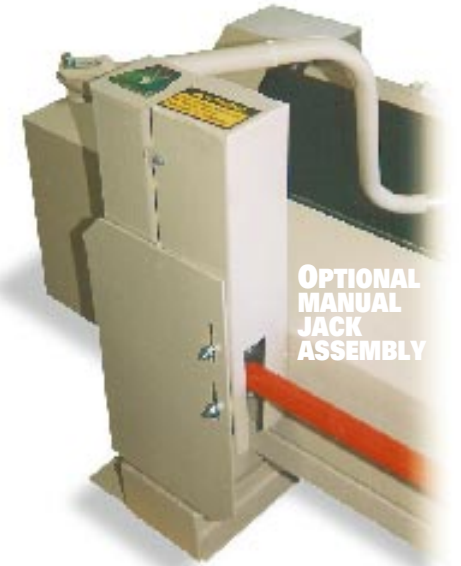
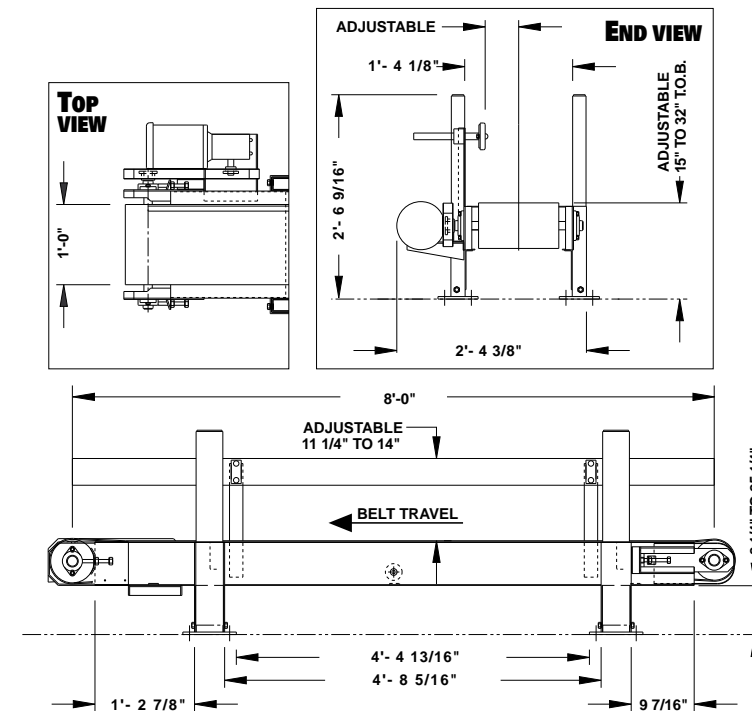
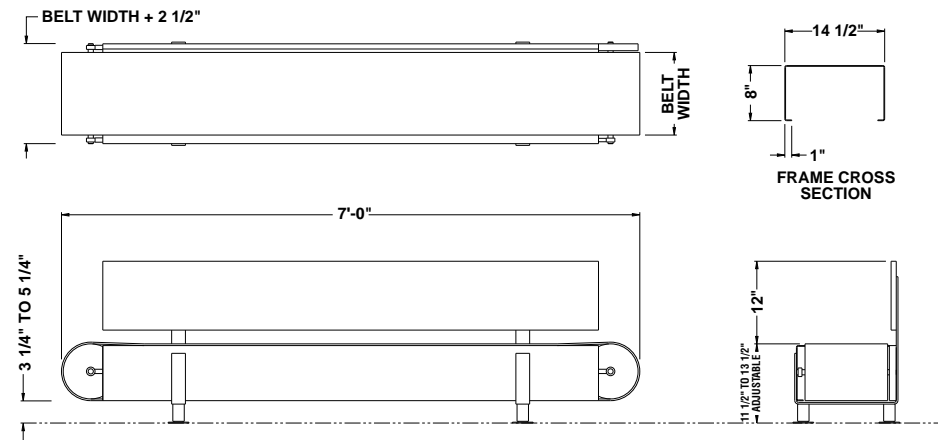

## SERIES B/HDB OPTIONS

■ **MANUAL JACK ASSEMBLY** - Dual-screw jacks with common connecting shaft assures level conveying at any height. Provides 12" of adjustment.

■ **ELECTRIC LIFT** - The same common-sense features of the manual jack assembly with the addition of a right angle worm gear reducer and 1/2 hp motor.

■ **CASTERS** - Four swivel casters allow you to use the same conveyor for multiple bagging operations within your plant.

■ **BAG KICKER** - Receives bags in an upright position and "kicks" them to horizontal at a 90 degree angle to the conveyor.

■ **BAG FLATTENER** - Dual conveyors with common adjustments to evenly distribute more difficult materials to prepare them for palletizing.

■ **BAG TURNER** - Changes direction of the filled bags along your bagging line.

■ **CUSTOM SPECIFICATIONS** - Any conveyor width, length or option can be custom configured to handle packaged product within your plant.

## SERIES B CONVEYOR

The Rapat Series B Belt Conveyor is an economical slider bed conveyor for light to medium-duty bagging operations.

Reduce labor costs and increase productivity without the expense of an elaborate conveying system. This conveyor may be used in conjunction with portable sewing equipment or with a stationary sewing pedestal.

## SERIES B SPECIFICATIONS

<b>Lengths</b> (Outside of pulleys)	Standard horizontal length is 7 feet. Optional lengths available to 14 feet.
<b>Belt</b>	12" wide, 120# smooth PVC belt with mechanical belt fastener. Belt speed is 35 FPM.
<b>Drive</b>	Roller chain final drive mounted inside the conveyor frame to protect operator.
<b>Frame</b>	12 gauge formed and welded steel slider bed.
<b>Power</b>	115V TEFC single phase gearmotor. 1/4 hp for 7' through 10' lengths. 1/2 hp for 11' through 14' lengths.
<b>Pulleys</b>	8" diameter head and tail pulleys.
<b>Supports</b>	Pipe leveling legs for 12" to 16" top of belt heights.

All specifications subject to change without notice.

## SERIES HDB CONVEYOR

The Rapat Series HDB Belt Conveyor is built for rugged bagging applications.

From the formed framework to the heavy-duty shafts and bearings, the HDB Conveyor is designed for long, hard hours of dependable service.

By incorporating the adjustable dual screw jack assembly, top of belt heights may be adapted to accommodate your full range of bagged product.

## SERIES HDB SPECIFICATIONS

<b>Lengths</b> (Centerline of pulleys)	Standard horizontal length is 8 feet. Optional lengths available to 14 feet.
<b>Belt</b>	12" wide, 120# smooth PVC belt with mechanical belt fastener. Belt speed is 40 FPM.
<b>Drive</b>	Right angle worm gear reducer with roller chain final drive.
<b>Frame</b>	12 gauge formed and welded steel slider bed for maximum bag support
<b>Power</b>	1/2 hp TEFC 3 phase C face motor is standard through 10'. 1 hp for 11' through 14' lengths. Other options available upon request.
<b>Pulleys</b>	6" diameter head and tail pulleys with 1 1/4" regreasable cast bearings.
<b>Supports</b>	2" x 4" structural tubing for 15" to 32" top of belt heights.

**HUNTSMAN, INC**  
Packaging, Processing and Dust Control

2362 Warren Ave.  
Twin Falls, ID 83301  
mail@huntsmanc.com

Ph. (208) 733-2214  
Toll Free: (888) 812-3377  
Fax: (208) 733-2240