

SERIES CU CONVEYOR



DISCHARGE SPOUT

The optional discharge spout funnels material to controlled openings such as bucket elevators and small inlet hoppers. Note that clearance heights are reduced when spout is installed (see spout detail illustration inside).



SERIES F CONVEYOR

The Series F Conveyor is the perfect teammate for our Series CU Conveyor! This combination is ideal for unloading hopper bottomed railcars, trucks and bins.



FLEXIBLE POWER OPTIONS

The Rapat Series CU Conveyor features a variety of power options— including Gas Engine, Electric Motor and Hydraulic drive.

Please contact your Rapat representative for more information about power options and applications.

RAPAT CORPORATION PRODUCT LINE CARD

CONVEYORS

- ENCLOSED BELT
- BAGGING
- CLEATED BELT
- TRUCK & RAILCAR UNLOADERS
- FLEXIBLE SIDEWALL
- PORTABLE BELT
- FOOD HANDLING
- TROUGHING ROLLER
- PLASTIC & WIRE BELTS
- SLIDER BED
- STAINLESS STEEL CONSTRUCTION
- EN-MASSE (DRAG)
- CUSTOM CONVEYORS

DISTRIBUTORS

- ROTO-FLO
- ROTARY VALVE
- SWING-FLO

BUCKET ELEVATORS

- COMPLETE BUCKET ELEVATOR ASSEMBLIES
- CUSTOM ACCESSORIES
- BACKLEG ROLL OPTIONS

SCREW CONVEYORS

- TUBE TYPE SCREW CONVEYORS
- AUGER FLIGHTING

HORIZONTAL UNLOAD POWERHEADS

- 25 DEGREE INCLINE POWERHEADS
- BIN UNLOAD TUBES WITH ROLLER SLIDE GATES
- BANJO SUMP BIN UNLOAD TUBES
- ELECTRIC / HYDRAULIC DRIVE KITS

ACCESSORIES

- HOPPER CAR UNLOADERS
- TRANSFER SPOUTING
- CAST IRON TURNHEADS
- REVERSIBLE ELBOWS
- DRAW OFF SPOUTS

INDUSTRIAL MATERIAL HANDLING SOLUTIONS THAT WORK!

At The Rapat Corporation, we approach each project with the intent of finding a better way to solve our customers' problems by listening to their individual needs, and applying what we learn to best solve their specific material handling requirements.

Put our experience with some of the largest Fortune 500 Corporations to work for you— call toll-free today for more information.

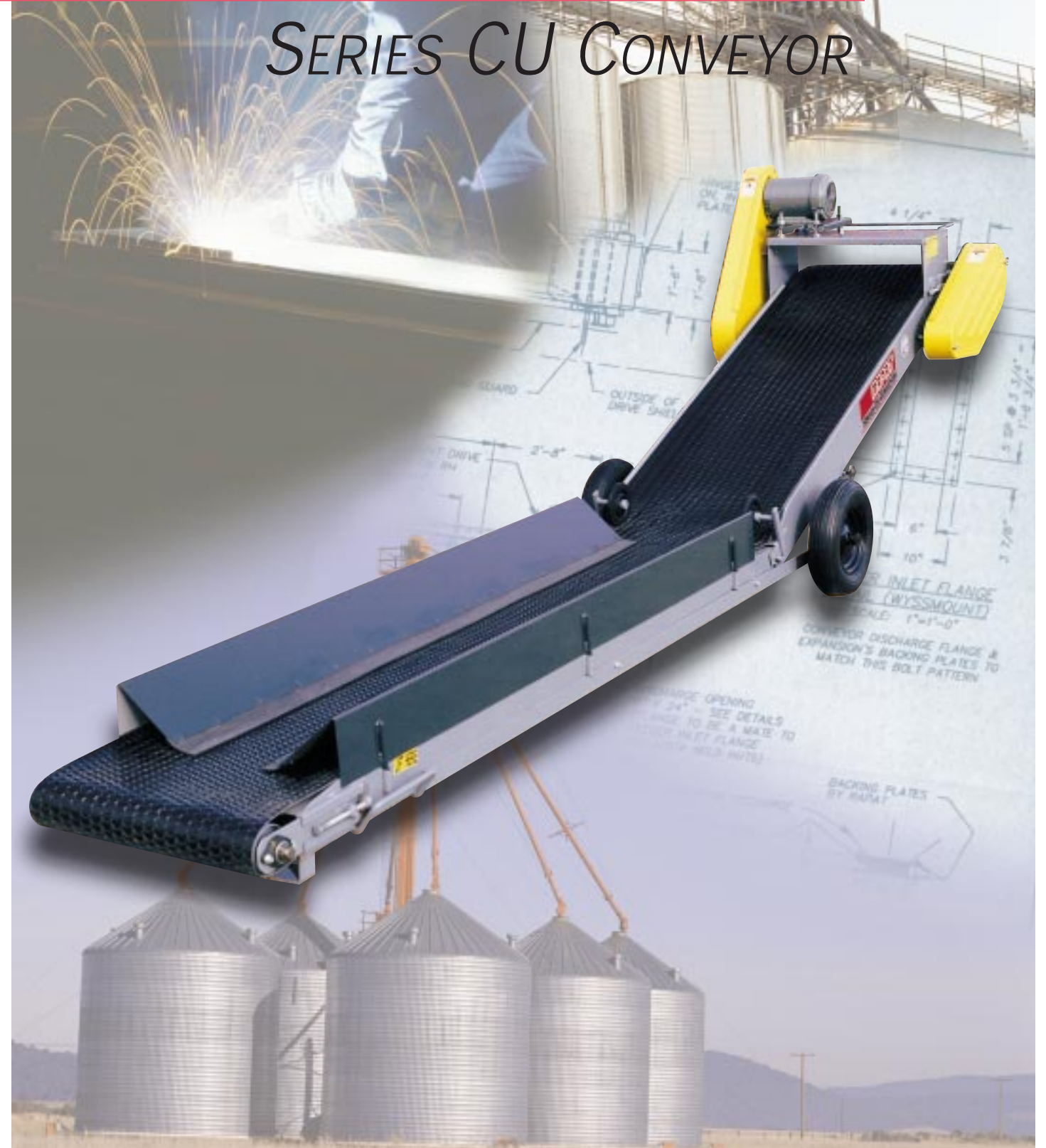

Series CU Conveyor FEATURES

SERIES CU CONVEYORS

The Series CU (Car Unloader) Conveyor is the answer for unloading bulk materials such as beans, grains, sand and fertilizer from controlled-opening hopper-bottomed railcars and trailers.

It is built for rugged use, handling up to 90 tons of material per hour on the 24" wide belt, and 120 tons of material per hour on the 30" wide belt (based on 60# per cubic foot material).

The Series CU Conveyor is equipped with a wheeled undercarriage, located at the conveyor's balance point for convenient one-person positioning.

Initially designed for truck and railcar unloading, the Series CU Conveyor has been used for unloading hopper-bottom tanks, for receiving product from low clearance conveyors and load out augers, and anywhere products require an efficient, gentle transfer of material.

The Series CU Conveyor features heavy-duty construction and common-sense design, reducing down-time and increasing your bottom line.

SERIES CU SPECIFICATIONS

Lengths	Standard horizontal length is 8 feet. Incline lengths are 5' through 14'.
Belt	18", 24", 30" and 36" wide PVC crescent top belt.
Drive	V-belt and roller chain drive the conveyor via two 4" rollers.
Frame	Formed and welded steel frame with self-cleaning bed.
Power	The Rapat Series CU Conveyor features a variety of power options— including Gas Engine, Electric Motor and Hydraulic Drive.
Undercarriage	Adjustable incline with 16" diameter pneumatic tires.
Pulleys	4" diameter head and snub pulleys with drum type tail pulley.
Hopper Sides	7' long skirted hopper sides. Removable for rail car unloading.

All specifications subject to change without notice.

SERIES CU CONVEYORS HAVE THE FEATURES YOU NEED!

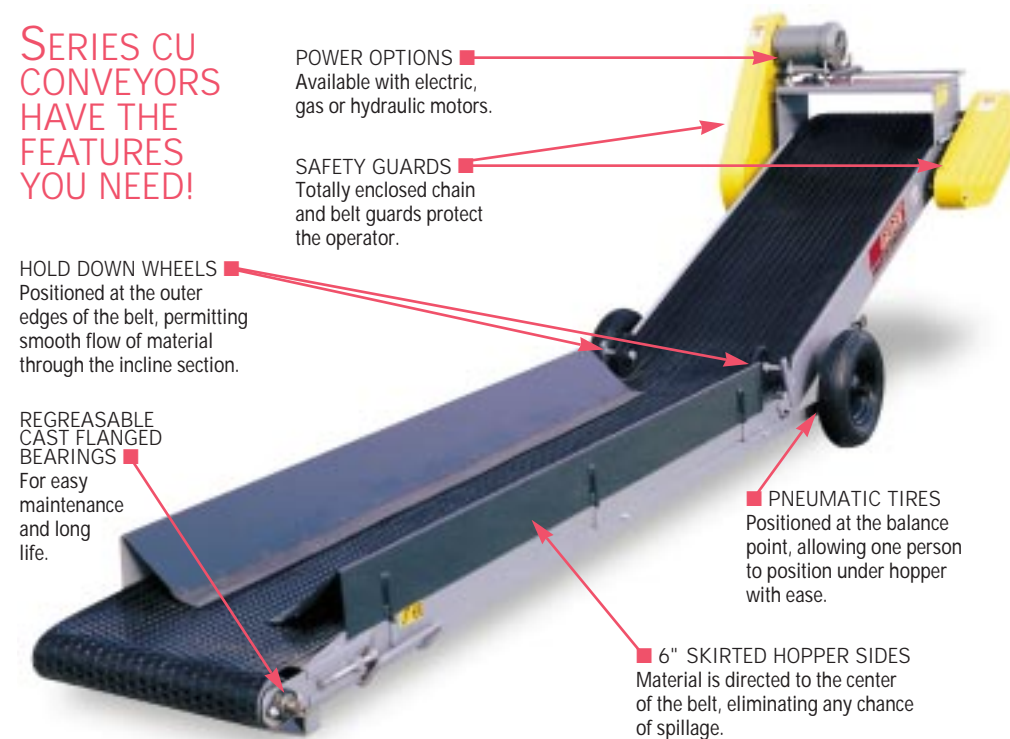

SERIES CU OPTIONS

■ DISCHARGE SPOUT - Designed for easy transfer of materials from Series CU Conveyor to small openings such as bucket elevator inlet hoppers. Available with optional rubber lining.

■ ELECTRIC MOTOR, GAS OR HYDRAULIC DRIVE - All Rapat conveyors are available with various power options.

■ 304 STAINLESS STEEL CONSTRUCTION - For corrosive applications.

■ SWIVEL CASTERS - Mounted at the end of the horizontal section. Allows for easier positioning on level surfaces.

■ BELT WIDTHS - The Series CU Conveyor is available in 18", 24", 30" and 36" belt widths.

■ SWING AWAY ADAPTER - Provides a pivot point for permanent installations, allowing the Series CU Conveyor to be swung under a truck or railcar, and easily moved when unloading operation is completed. Includes four swivel casters in place of pneumatic tires.

■ HIGH CLEARANCE MOTOR MOUNT - Designed for moving larger product such as earcorn, range cubes or recyclables.

■ SELF-CLEANING TAIL PULLEY - Reduces material clogging and potential damage.

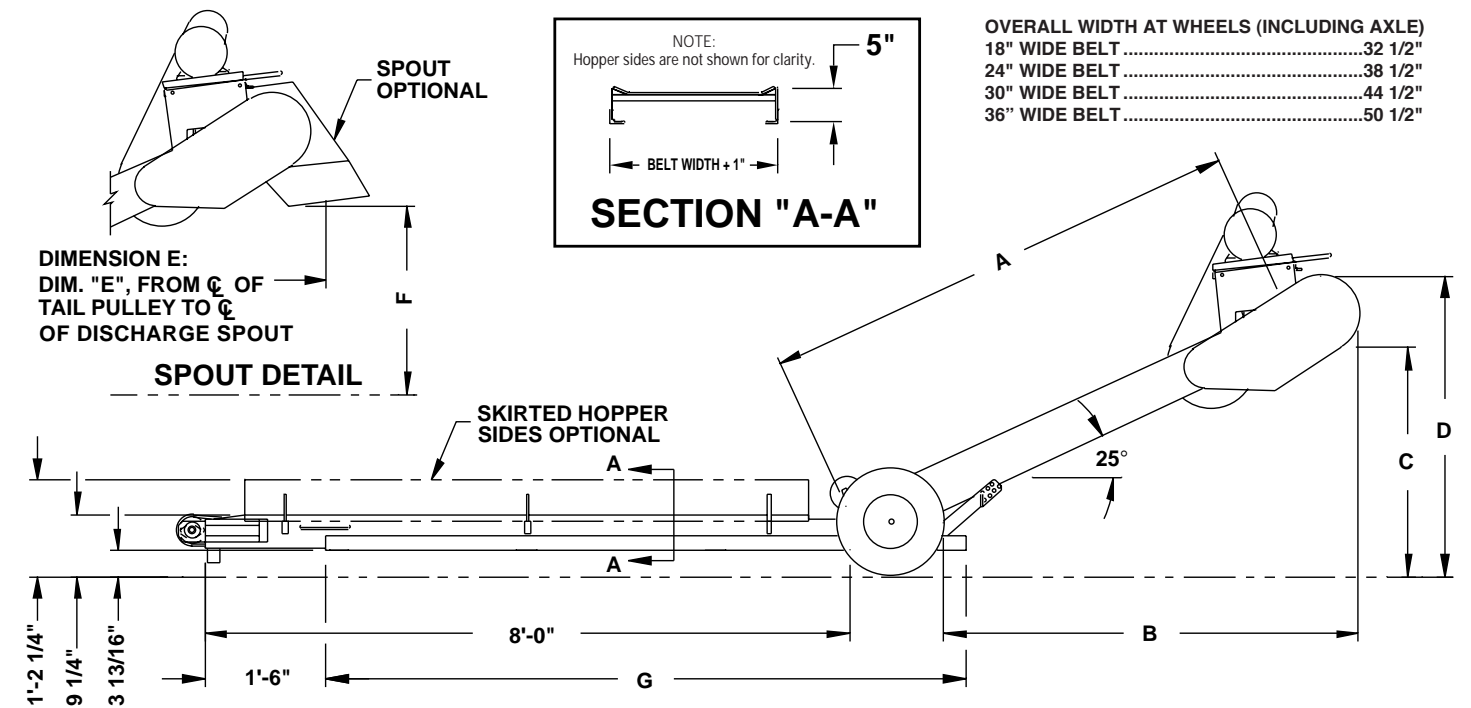

OVERALL WIDTH AT WHEELS (INCLUDING AXLE)

18" WIDE BELT	32 1/2"
24" WIDE BELT	38 1/2"
30" WIDE BELT	44 1/2"
36" WIDE BELT	50 1/2"

SERIES CU CONVEYOR DIMENSIONS

Model	A	B	C	D	E	F	G
85	5'- 0"	4' - 3"	2' - 5"	3' - 3 3/4"	13' - 10"	1' - 10 3/4"	7' - 7"
86	6'- 0"	5' - 1 3/4"	2' - 10"	3' - 9"	14' - 8 3/4"	2' - 3 3/4"	8' - 0"
87	7'- 0"	6' - 3/4"	3' - 3"	4' - 2"	15' - 7 3/4"	2' - 8 3/4"	8' - 5"
88	8'- 0"	6' - 11 1/2"	3' - 8 1/4"	4' - 7"	16' - 6 1/2"	3' - 2"	8' - 9"
89	9'- 0"	7' - 10 1/2"	4' - 1 1/4"	5' - 0"	17' - 5 1/2"	3' - 7"	9' - 4"
810	10'- 0"	8' - 9 1/4"	4' - 6 1/4"	5' - 5"	18' - 4 1/4"	4' - 0"	10' - 0"
811	11'- 0"	9' - 8 1/4"	4' - 11 1/4"	5' - 10 1/4"	19' - 3 1/4"	4' - 5"	11' - 0"
812	12'- 0"	10' - 7"	5' - 4 1/2"	6' - 3 1/4"	20' - 2"	4' - 10 1/4"	12' - 0"
813	13'- 0"	11' - 6"	5' - 9 1/2"	6' - 8 1/4"	21' - 1"	5' - 3 1/4"	12' - 7"
814	14'- 0"	12' - 4 3/4"	6' - 2 1/2"	7' - 1 1/2"	21' - 11 3/4"	5' - 8 1/4"	13' - 0"

STANDARD MOTOR HORSEPOWER RATING

	85	86	87	88	89	810	811	812	813	814
18"	1 1/2 hp	1 1/2 hp	1 1/2 hp	1 1/2 hp	1 1/2 hp	2 hp	2 hp	2 hp	2 hp	2 hp
24"	2 hp	2 hp	2 hp	2 hp	2 hp	3 hp	3 hp	3 hp	3 hp	3 hp
30"	3 hp	3 hp	3 hp	3 hp	3 hp	3 hp	5 hp	5 hp	5 hp	5 hp
36"	5 hp	5 hp	5 hp	5 hp	5 hp	7 1/2 hp	7 1/2 hp	7 1/2 hp	7 1/2 hp	7 1/2 hp

Please consult factory engineering department prior to proceeding with any measurement critical planning.

HUNTSMAN, INC
Packaging, Processing and Dust Control

2362 Warren Ave. Ph. (208) 733-2214
Twin Falls, ID 83301 Toll Free: (888) 812-3377
mail@huntsmanc.com Fax: (208) 733-2240

SPILL-FREE OPERATION

Our extra-wide belt permits a smooth flow of materials through the transition, away from the hold-down wheels and belt edges.

