

SCC Bucket Elevators For a Variety of Applications

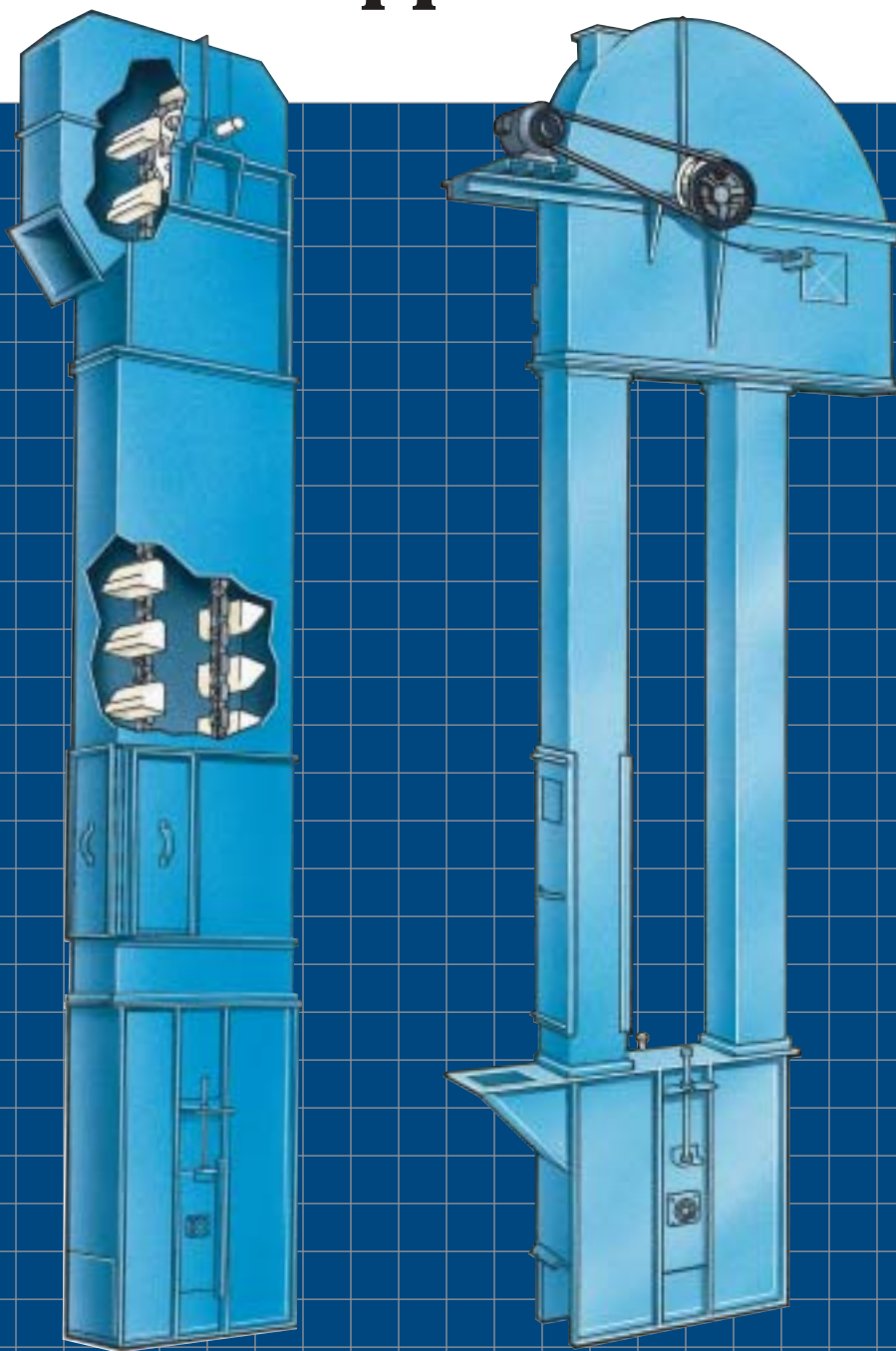

**THE EXPERIENCE
TO HANDLE IT RIGHT!**

Screw Conveyor Corporation®

SCC Bucket Elevators...

Long Life, Rugged Service, and a Wide Range of Applications

SCC Bucket Elevators offer an economical, efficient and reliable means of elevating a wide variety of dry, free-flowing bulk materials. SCC experience, as one of the largest exclusive producers of bulk materials handling equipment – plus new NU-WELD® weather-tight or dust-tight casing construction – means low maintenance, long service.

SCC Centrifugal Type Bucket Elevator – recommended for handling fine, free-flowing materials which can be dug from the elevator boot. Small lumps, as listed for standard elevators, can be handled – providing buckets of proper size are used. The feed point is lower, loading

is simpler and fewer buckets are required than for the Continuous Type Bucket Elevator. Buckets on chain or belt travel at speeds high enough to discharge materials by centrifugal force as they pass around the head pulley or sprocket.

SCC Continuous Type Elevator – recommended for handling sluggish, aerated and friable material and material having a large percentage of lumps. Continuously spaced buckets travel at slower speeds than the centrifugal type. The buckets are designed so that the fronts and extended sides form a chute as they pass around the head pulley or sprocket. Gravity causes the material

to flow gently out of the buckets and down the chute, formed by the preceding buckets, into the discharge spout.

SCC Double Trunk High Capacity Bucket Elevators – The SCC Bucket elevator has been designed and engineered to provide efficient high capacities for handling various grains, feeds, mill stock and similar free flowing granular materials. It is manufactured in many different sizes to suit individual requirements. It has double trunk legging construction with connecting angles provided on each 10 foot flange section. Vertical angle supports are included on taller units.

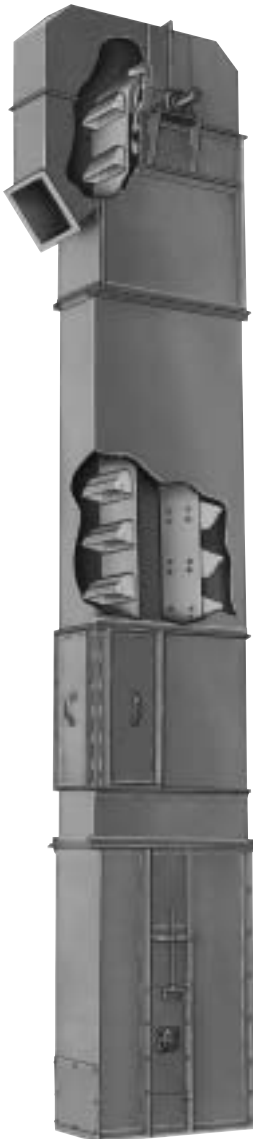

SCC Construction Features Mean Longer Service Life, Efficient and Economical Performance.

■ Head Section completely factory assembled. Split head insures easy access or removal for maintenance. Convenient inspection door. Bearings on head shaft are engineered for maximum load requirements which reduces friction and assures smooth operation. Head shaft take-ups can be furnished where necessary.

■ Discharge spout has 45° flange and convenient inspection door furnished as standard. Can be supplied with horizontal flange if preferred.

■ SCC Bucket Elevators are supplied with chain or belt. Type of chain or belt specification dependent on application.

■ Buckets are style "AA" Malleable Iron or steel buckets, or polymer for centrifugal elevators. "Hammond", Continuous Type Steel Buckets or Cast nylon are used on continuous elevators.

■ NU-WELD® casing construction provides exceptional strength, dimensional stability and weather protection. Two large doors provide easy access for maintenance and cleaning.

■ Boot Section is completely factory assembled. Heavy ball bearing take-ups provide for adequate chain or belt adjustment. One side of boot is bolted to provide easy access to inside of boot. Two bolted clean-out panels are included.

Internal gravity take-up is available for harsh environments or dust control. External gravity take-up is available for rugged heavy duty applications.

Wing type self-cleaning boot pulleys are standard. Head pulleys with vulcanized or replaceable lagging are available.

■ Unless otherwise specified, or required because of elevator height or application, standard construction will be furnished which incorporates the boot of 10 gauge steel and the casing and head of 12 gauge steel. Guy wires for bracing are not included.

■ Traction wheels for chain leg models are available – solid or segmented. Solid and segmented sprocket and solid or split hub are also available.

■ Stainless steel construction of housing, buckets, pulley and fabricated parts is available for special applications such as food, animal feed or handling of corrosive materials.

New NU-WELD® Casing Construction

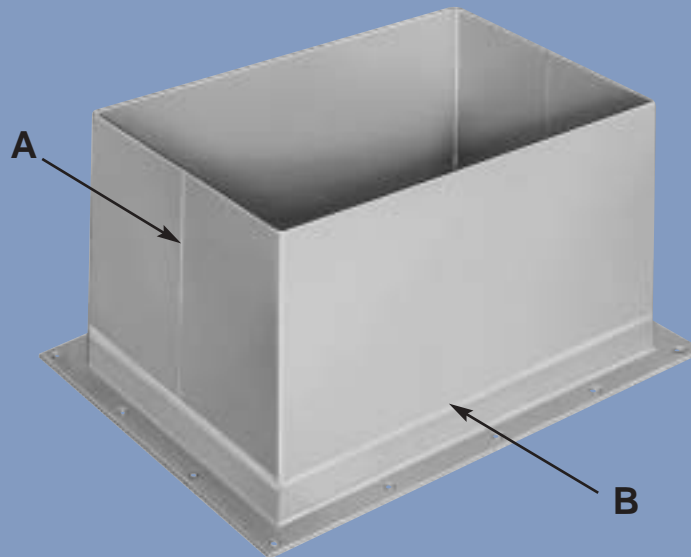

A. Heavy-gauge formed steel sections continuously submerged arc seam welded for full length. Provides greater strength, dimensional stability and weather-tight construction.

B. Fixture positioned angle and flange frames, continuously seal welded, assure proper alignment in field erection.

Note: For complete weather-tight installation, gaskets should be included for all shop and field bolted connections.

Choose the Style That Works Best For Your Application.



CEB



CEC



COB



COC

				DIMENSIONS (Inches)										
ELEVATOR MODEL NUMBER				A	B	C	D	E	F	G	H	J	K	L
CEB 6420	CEC 6420			12	35	13	17 ¹ / ₂	30 ³ / ₄	20 ¹ / ₂	27 ¹ / ₂	9	9 ³ / ₄	10	23 ¹ / ₂
CEB 8520	CEC 8520	COB 8520	COC 8520	14	39	15	19 ¹ / ₂	32 ³ / ₄	22	29 ¹ / ₂	9	11 ³ / ₄	10	24 ³ / ₄
CEB 8524	CEC 8524			14	42	15	21	36 ³ / ₈	23 ³ / ₄	30 ¹ / ₄	9	11 ³ / ₄	13	26 ⁵ / ₈
COB 10520	COC 10520			16	42	17	21	36 ³ / ₈	23 ³ / ₄	30 ¹ / ₄	9	13 ³ / ₄	13	25 ⁷ / ₈
CEB 10620	CEC 10620			16	42	17	21	36 ³ / ₈	23 ³ / ₄	30 ¹ / ₄	9	13 ³ / ₄	13	25 ⁷ / ₈
CEB 10624	CEC 10624	COC 10724		16	48	17	24	40 ³ / ₄	27 ¹ / ₄	33 ³ / ₄	9	13 ³ / ₄	15	29
CEB 12724	CEC 12724	COB 12724	COC 12724	18	48	20	24	40 ³ / ₄	27 ¹ / ₄	33 ³ / ₄	9	15 ³ / ₄	15	29
CEB 12730	CEC 12730			18	54	20	27	45 ¹ / ₈	31	36 ¹ / ₂	9	15 ³ / ₄	17	30 ⁷ / ₈
CEB 14724	CEC 14724	COB 14724	COC 14724	20	48	22	24	40 ³ / ₄	27 ¹ / ₄	33 ³ / ₄	9	17 ³ / ₄	15	29 ¹ / ₄
CEB 14730	CEC 14730	COB 14824	COC 14824	20	54	22	27	45 ¹ / ₈	31	36 ¹ / ₂	9	17 ³ / ₄	17	30 ⁷ / ₈
CEB 16824	CEC 16824	COB 16824	COC 16824	22	48	24	24	40 ³ / ₄	27 ¹ / ₄	33 ³ / ₄	12	19 ³ / ₄	15	32 ¹ / ₄
CEB 16830	CEC 16830			22	54	24	27	45 ¹ / ₈	31	36 ¹ / ₂	12	19 ³ / ₄	17	34 ¹ / ₂
COB 18824	COC 18824			24	48	26	24	40 ³ / ₄	27 ¹ / ₄	33 ³ / ₄	12	21 ³ / ₄	15	32 ¹ / ₄

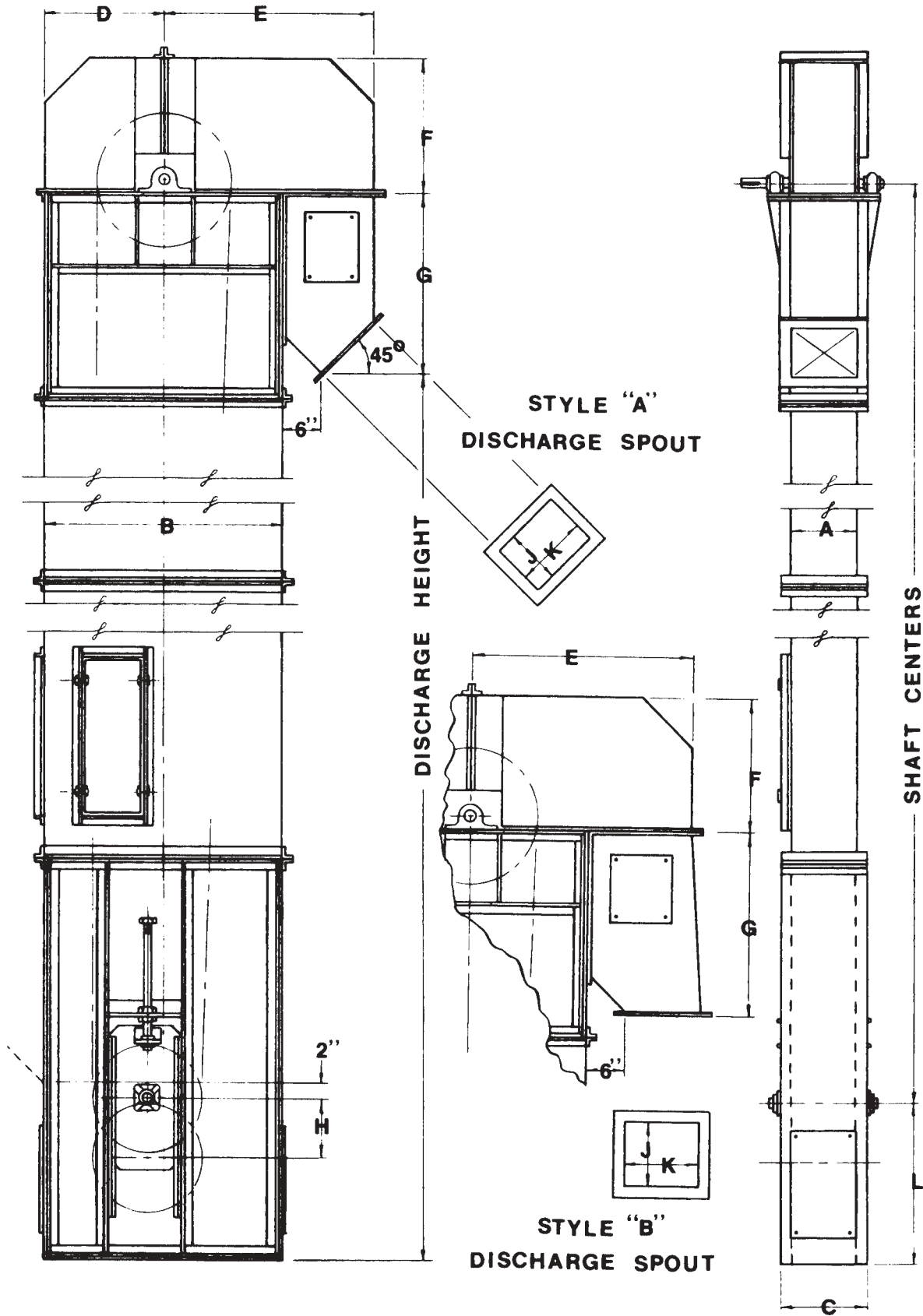

SERIES CEB Centrifugal Belt Type Elevator

BELTS: Elevator belts are normally friction surface belts. Rubber covered, synthetic, nylon, heat resistant or duck body PVC belts can be furnished depending upon material application.

BUCKETS: Style AA or Style AARB buckets are normally furnished. Style AA buckets are available in malleable iron, ductile iron, welded steel construction, nylon, urethane and polyethylene. Style AARB buckets available in malleable iron.

DRIVES: Shaft mounted gear reducer with built-in backstop and V-belt drive is recommended for economy and versatility. Gearhead motors with chain drives can also be furnished. External shaft mounted backstops are also available. Drive guards are furnished for safety.

MODEL		CAPACITY			
CEB 6420	6 x 4 x 4 ¹ / ₄	225 F.P.M.	43 R.P.M.	280 Cu. Ft.	
Specifications & Dimensions:	Head Pulley 20" Dia. x 8" F	Bucket Spacing 13"	Boot Pulley 16" Dia. x 8" F.	Tail Shaft 1 ⁷ / ₁₆ " Dia.	Per Hour
CEB 8520	8 x 5 x 5 ¹ / ₂	225 F.P.M.	43 R.P.M.	535 Cu. Ft.	
Specifications & Dimensions:	Head Pulley 20" Dia. x 10" F.	Bucket Spacing 16"	Boot Pulley 16" Dia. x 10" F.	Tail Shaft 1 ⁷ / ₁₆ " Dia.	Per Hour
CEB 8524	8 x 5 x 5 ¹ / ₂	260 F.P.M.	41 R.P.M.	614 Cu. Ft.	
Specifications & Dimensions:	Head Pulley 24" Dia. x 10" F.	Bucket Spacing 16"	Boot Pulley 20" Dia. x 10" F.	Tail Shaft 1 ¹⁵ / ₁₆ " Dia.	Per Hour
CEB 10620	10 x 6 x 6 ¹ / ₄	225 F.P.M.	43 R.P.M.	910 Cu. Ft.	
Specifications & Dimensions:	Head Pulley 20" Dia. x 12" F.	Bucket Spacing 16"	Boot Pulley 16" Dia. x 12" F.	Tail Shaft 1 ¹⁵ / ₁₆ " Dia.	Per Hour
CEB 10624	10 x 6 x 6 ¹ / ₄	260 F.P.M.	41 R.P.M.	1051 Cu. Ft.	
Specifications & Dimensions:	Head Pulley 24" Dia. x 12" F.	Bucket Spacing 16"	Boot Pulley 20" Dia. x 12" F.	Tail Shaft 1 ¹⁵ / ₁₆ " Dia.	Per Hour
CEB 12724	12 x 7 x 7 ¹ / ₄	260 F.P.M.	41 R.P.M.	1482 Cu. Ft.	
Specifications & Dimensions:	Head Pulley 24" Dia. x 14" F	Bucket Spacing 18"	Boot Pulley 20" Dia. x 14" F.	Tail Shaft 1 ¹⁵ / ₁₆ " Dia.	Per Hour
CEB 12730	12 x 7 x 7 ¹ / ₄	300 F.P.M.	38 R.P.M.	1710 Cu. Ft.	
Specifications & Dimensions:	Head Pulley 30" Dia. x 14" F.	Bucket Spacing 18"	Boot Pulley 24" Dia. x 14" F.	Tail Shaft 1 ¹⁵ / ₁₆ " Dia.	Per Hour
CEB 14724	14 x 7 x 7 ¹ / ₄	260 F.P.M.	41 R.P.M.	1793 Cu. Ft.	
Specifications & Dimensions:	Head Pulley 24" Dia. x 16" F.	Bucket Spacing 18"	Boot Pulley 20" Dia. x 16" F.	Tail Shaft 2 ³ / ₁₆ " Dia.	Per Hour
CEB 14730	14 x 7 x 7 ¹ / ₄	300 F.P.M.	38 R.P.M.	2070 Cu. Ft.	
Specifications & Dimensions:	Head Pulley 30" Dia. x 16" F.	Bucket Spacing 18"	Boot Pulley 24" Dia. x 16" F.	Tail Shaft 2 ³ / ₁₆ " Dia.	Per Hour
CEB 16824	16 x 8 x 8 ¹ / ₂	260 F.P.M.	41 R.P.M.	2652 Cu. Ft.	
Specifications & Dimensions:	Head Pulley 24" Dia. x 18" F.	Bucket Spacing 18"	Boot Pulley 20" Dia. x 18" F.	Tail Shaft 2 ³ / ₁₆ " Dia.	Per Hour
CEB 16830	16 x 8 x 8 ¹ / ₂	300 F.P.M.	38 R.P.M.	3060 Cu. Ft.	
Specifications & Dimensions:	Head Pulley 30" Dia. x 18" F.	Bucket Spacing 18"	Boot Pulley 24" Dia. x 18" F.	Tail Shaft 2 ³ / ₁₆ " Dia.	Per Hour

SERIES CEC Centrifugal Chain Type Elevator

CHAINS: Combination chains with alternating cast iron block links are used for light to normal operating conditions. Heat treated chain is also available for greater strength and wear resistance. "S" class steel chains are recommended for elevators of greater height, operating continuously, or handling abrasive materials.

BUCKETS: Style AA or Style AARB buckets are normally furnished. Style AA buckets are available in malleable iron, ductile iron, welded steel construction, nylon, urethane and polyethylene. Style AARB available in malleable iron.

DRIVES: Shaft mounted gear reducer with built-in backstop and V-belt drive is recommended for economy and versatility. Gearhead motors with chain drives can also be furnished. External shaft mounted backstops are also available. Drive guards are furnished for safety.

MODEL		CAPACITY			
CEC 6420	6 x 4 x 4 ¹ / ₂	188 Chain K-1	230 F.P.M.	43 R.P.M.	288 Cu. Ft.
Specifications & Dimensions:	Head Sprocket 19.9	Spacing 13"	Boot Sprocket 15.0	Boot Shaft 1 ⁷ / ₁₆ " Dia.	Per Hour
CEC 8520	8 x 5 x 5 ¹ / ₂	102 B Chain K-2	230 F.P.M.	43 R.P.M.	543 Cu. Ft.
Specifications & Dimensions:	Head Sprocket 20.5	Spacing 16"	Boot Sprocket 15.5	Boot Shaft 1 ⁷ / ₁₆ " Dia.	Per Hour
CEC 8524	8 x 5 x 5 ¹ / ₂	102 B Chain K-2	260 F.P.M.	41 R.P.M.	614 Cu. Ft.
Specifications & Dimensions:	Head Sprocket 24.3	Spacing 16"	Boot Sprocket 19.2	Boot Shaft 1 ¹⁵ / ₁₆ " Dia.	Per Hour
CEC 10620	10 x 6 x 6 ¹ / ₄	102 B Chain K-2	230 F.P.M.	43 R.P.M.	930 Cu. Ft.
Specifications & Dimensions:	Head Sprocket 20.5	Spacing 16"	Boot Sprocket 15.5	Boot Shaft 1 ¹⁵ / ₁₆ " Dia.	Per Hour
CEC 10624	10 x 6 x 6 ¹ / ₄	102 B Chain K-2	260 F.P.M.	41 R.P.M.	1051 Cu. Ft.
Specifications & Dimensions:	Head Sprocket 24.3	Spacing 16"	Boot Sprocket 19.2	Boot Shaft 1 ¹⁵ / ₁₆ " Dia.	Per Hour
CEC 12724	12 x 7 x 7 ¹ / ₄	102 B Chain K-2	260 F.P.M.	41 R.P.M.	1668 Cu. Ft.
Specifications & Dimensions:	Head Sprocket 24.3	Spacing 16"	Boot Sprocket 19.2	Boot Shaft 1 ¹⁵ / ₁₆ " Dia.	Per Hour
CEC 12730	12 x 7 x 7 ¹ / ₄	S 110 Chain K-2	310 F.P.M.	38 R.P.M.	1768 Cu. Ft.
Specifications & Dimensions:	Head Sprocket 30.8	Spacing 18"	Boot Sprocket 23.2	Boot Shaft 1 ¹⁵ / ₁₆ " Dia.	Per Hour
CEC 14724	14 x 7 x 7 ¹ / ₄	S 110 Chain K-2	270 F.P.M.	41 R.P.M.	1862 Cu. Ft.
Specifications & Dimensions:	Head Sprocket 25.1	Spacing 18"	Boot Sprocket 19.4	Boot Shaft 2 ³ / ₁₆ " Dia.	Per Hour
CEC 14730	14 x 7 x 7 ¹ / ₄	S 110 Chain K-2	310 R.P.M.	38 R.P.M.	2138 Cu. Ft.
Specifications & Dimensions:	Head Sprocket 30.8	Spacing 18"	Boot Sprocket 23.2	Boot Shaft 2 ³ / ₁₆ " Dia.	Per Hour
CEC 16824	16 x 8 x 8 ¹ / ₂	S 110 Chain K-2	250 F.P.M.	41 R.P.M.	2550 Cu. Ft.
Specifications & Dimensions:	Head Sprocket 23.2	Spacing 18"	Boot Sprocket 19.4	Boot Shaft 2 ³ / ₁₆ " Dia.	Per Hour
CEC 16830	16 x 8 x 8 ¹ / ₂	S 110 Chain K-2	310 F.P.M.	38 R.P.M.	3160 Cu. Ft.
Specifications & Dimensions:	Head Sprocket 30.8	Spacing 18"	Boot Sprocket 23.2	Boot Shaft 2 ³ / ₁₆ " Dia.	Per Hour

SERIES COB Continuous Belt Type Elevator

BELTS: Elevator belts are normally friction surface belts. Rubber covered, synthetic, nylon, heat resistant or duck body PVC belts can be furnished depending upon materials application.

BUCKETS: Hammond Continuous Steel Buckets are of rugged construction, continuously welded, for handling materials of a bulky or gritty nature, such as crushed stone, coal, ore, etc. Hammond Continuous Buckets available in Low Front, Medium Front, High Front, Overlapping and Non-Overlapping. Continuous Medium Front Non Overlapping buckets also available in nylon, urethane and polyethylene.

DRIVES: Shaft mounted gear reducer with built-in backstop and V-belt drive is recommended for economy and versatility. Gearhead motors with chain drives can also be furnished. External shaft mounted backstops are also available. Drive guards are furnished for safety.

MODEL					CAPACITY
COB 8520	8 x 5 x 7 ³ / ₄	125 F.P.M.	24 R.P.M.	675 Cu. Ft.	
Specifications & Dimensions:	Head Pulley 20" Dia. x 10" F.	Bucket Spacing 8"	Boot Pulley 16" Dia. x 10" F.	Tail Shaft 1 ⁷ / ₁₆ " Dia.	Per Hour
COB 10520	10 x 5 x 7 ³ / ₄	125 F.P.M.	24 R.P.M.	842 Cu. Ft.	
Specifications & Dimensions:	Head Pulley 20" Dia. x 12" F.	Bucket Spacing 8"	Boot Pulley 16" Dia x 12" F.	Tail Shaft 1 ¹⁵ / ₁₆ " Dia.	Per Hour
COB 12724	12 x 7 x 11 ⁵ / ₈	125 F.P.M.	20 R.P.M.	1293 Cu. Ft.	
Specifications & Dimensions:	Head Pulley 24" Dia. x 14" F.	Bucket Spacing 12"	Boot Pulley 20" Dia. x 14" F.	Tail Shaft 1 ¹⁵ / ₁₆ " Dia.	Per Hour
COB 14724	14 x 7 x 11 ⁵ / ₈	125 F.P.M.	20 R.P.M.	1518 Cu. Ft.	
Specifications & Dimensions:	Head Pulley 24" Dia. x 16" F.	Bucket Spacing 12"	Boot Pulley 20" Dia x 16" F.	Tail Shaft 2 ³ / ₁₆ " Dia.	Per Hour
COB 14824	14 x 8 x 11 ⁵ / ₈	125 F.P.M.	20 R.P.M.	1815 Cu. Ft.	
Specifications & Dimensions:	Head Pulley 24" Dia. x 16" F.	Bucket Spacing 12"	Boot Pulley 20" Dia. x 16" F.	Tail Shaft 2 ³ / ₁₆ " Dia.	Per Hour
COB 16824	16 x 8 x 11 ⁵ / ₈	125 F.P.M.	20 R.P.M.	2080 Cu. Ft.	
Specifications & Dimensions:	Head Pulley 24" Dia. x 18" F.	Bucket Spacing 12"	Boot Pulley 20" Dia. x 18" F.	Tail Shaft 2 ³ / ₁₆ " Dia.	Per Hour
COB 18824	18 x 8 x 11 ⁵ / ₈	125 F.P.M.	20 R.P.M.	2340 Cu. Ft.	
Specifications & Dimensions:	Head Pulley 24" Dia. x 20" F.	Bucket Spacing 12"	Boot Pulley 20" Dia. x 20" F.	Tail Shaft 2 ³ / ₁₆ " Dia.	Per Hour

SERIES COC Continuous Chain Type Elevator

CHAINS: Combination chains with alternating cast iron block links are used for light to normal operating conditions. Heat treated chain is also available for greater strength and wear resistance. "S" Class steel chains are recommended for elevators of greater height, operating continuously, or handling abrasive materials.

BUCKETS: Hammond Continuous Steel Buckets are of rugged construction, continuously welded, for handling materials of a bulky or gritty nature, such as crushed stone, coal, ore, etc. Hammond Continuous Buckets available in Low Front, Medium Front, High Front, Overlapping and Non-Overlapping. Continuous Medium Front Non Overlapping buckets also available in nylon, urethane and polyethylene.

DRIVES: Shaft mounted gear reducer with built-in backstop and V-belt drive is recommended for economy and versatility. Gearhead motors with chain drives can also be furnished. External shaft mounted backstops are also available. Drive guards are furnished for safety.

MODEL					CAPACITY
COC 8520	8 x 5 x 7 ³ / ₄	102 B Chain K-2	125 F.P.M.	23.4 R.P.M.	675 Cu. Ft.
Specifications & Dimensions:	Head Sprocket 20.5	Spacing 8"	Boot Sprocket 15.5	Boot Shaft 1 ⁷ / ₁₆ " Dia.	Per Hour
COC 10520	10 x 5 x 7 ³ / ₄	102 B Chain K-2	125 F.P.M.	23.4 R.P.M.	842 Cu. Ft.
Specifications & Dimensions:	Head Sprocket 20.5	Spacing 8"	Boot Sprocket 15.5	Boot Shaft 1 ¹⁵ / ₁₆ " Dia.	Per Hour
COC 10724	10 x 7 x 11 ⁵ / ₈	110 Chain K-2	125 F.P.M.	19.1 R.P.M.	1080 Cu. Ft.
Specifications & Dimensions:	Head Sprocket 25.1	Spacing 12"	Boot Sprocket 19.4"	Boot Shaft 1 ¹⁵ / ₁₆ " Dia.	Per Hour
COC 12724	12 x 7 x 11 ⁵ / ₈	110 Chain K-2	125 F.P.M.	19.1 R.P.M.	1293 Cu. Ft.
Specifications & Dimensions:	Head Sprocket 25.1	Spacing 12"	Boot Sprocket 19.4	Boot Shaft 1 ¹⁵ / ₁₆ " Dia.	Per Hour
COC 14724	14 x 7 x 11 ⁵ / ₈	110 Chain K-2	125 F.P.M.	19.1 R.P.M.	1518 Cu. Ft.
Specifications & Dimensions:	Head Sprocket 25.1	Spacing 12"	Boot Sprocket 19.4	Boot Shaft 2 ³ / ₁₆ " Dia.	Per Hour
COC 14824	14 x 8 x 11 ⁵ / ₈	110 Chain K-2	125 F.P.M.	19.1 R.P.M.	1815 Cu. Ft.
Specifications & Dimensions:	Head Sprocket 2.12	Spacing 12"	Boot Sprocket 19.4	Boot Shaft 2 ³ / ₁₆ " Dia.	Per Hour
COC 16824	16 x 8 x 11 ⁵ / ₈	S 110 Chain K-2	125 F.P.M.	20.6 R.P.M.	2080 Cu. Ft.
Specifications & Dimensions:	Head Sprocket 23.2	Spacing 12"	Boot Sprocket 19.4	Boot Shaft 2 ³ / ₁₆ " Dia.	Per Hour
COC 18824	18 x 8 x 11 ⁵ / ₈	S 110 Chain K-2	125 F.P.M.	19.1 R.P.M.	2340 Cu. Ft.
Specifications & Dimensions:	Head Sprocket 25.1	Spacing 12"	Boot Sprocket 19.4	Boot Shaft 2 ³ / ₁₆ " Dia.	Per Hour

OPTIONS FOR ALL ELEVATORS

Zero speed switches, belt/chain alignment switches, motion probes, bearing temperature probes, internal gravity take ups, top take ups, telescoping take ups, A/R liners, galvanized construction, stainless construction, special paint and surface preparations plus many other options.

ELEVATOR BUCKETS METALLIC AND NON-METALLIC



POLYMER NYLON BUCKETS



MALLEABLE IRON BUCKETS



HAMMOND CONTINUOUS ELEVATOR BUCKETS

CAPACITY FORMULA

Capacity for a given installation in bushels per hour equals head pulley RPM times pulley circumference from Table I, times multiplier from Table II, times bucket length, times spacing multiplier from Table III.

TABLE I

Diameter of Head Pulley Inches	Pulley Circumference In Feet
12	3.14
16	4.18
18	4.71
20	5.23
24	6.28
30	7.85
36	9.42
42	10.99
48	12.57
54	14.14
60	15.71
72	18.84
84	21.99

TABLE II

Nominal Cup Projection, Inches	Multiplier
3	.15
4	.27
5	.43
6	.64
7	.85

TABLE III

Spacing Multiplier

for 4"	3.0	for 8"	1.5
5"	2.4	9"	1.33
5 ¹ / ₄ "	2.28	10"	1.2
6"	2.0	11"	1.09
6 ¹ / ₂ "	1.85	12"	1.0
7"	1.7	13"	.923
7 ³ / ₄ "	1.55	14"	.855
		16"	.75

HORSEPOWER FORMULA

FORMULA

$$HP = \frac{W \times H}{33,000}$$

(Add 10 to 20% depending on type of drive.)

W = Weight of material elevated per minute (divide bushels per hour by 60 and multiply by weight of material per bushel).

H = Vertical distance of lift in feet.

EXAMPLE

Figure horsepower for elevating 7393 bushels per hour of wheat weighing 60 lbs. per bushel: height of elevator 75 feet.

ANSWER:

$$W = \frac{7393 \times 60}{60} \text{ or } 7393$$

$$H = 75 \text{ foot lift}$$

$$HP = \frac{7393 \times 75}{33,000} \text{ or } 16.8$$

plus 10 to 20% (use 20 HP motor)

MATERIAL CLASSIFICATION CHART FOR SCC INDUSTRIAL BUCKET ELEVATORS

Material	Wt. Per Cu. Ft., Lbs.	Mat'l. Code	Type of Elevator	Material	Wt. Per Cu. Ft. Lbs.	Mat'l. Code	Type of Elevator
Alfalfa meal	14-22	B46Y	COC	Fluorspar Fine	80-100	C46	CEC
Almonds, broken	27-30	C36	CEC COC	Fullers' Earth, raw	30-40	D36	CEB
Almonds, whole	28-30	D36Q	COC	Fullers' Earth, spent	60-65	B37WX	CEB
Alum, lumpy	50-60	D35U	CEC COC	Glass batch	80-100	D37Z	CEB
Alum, pulverized	45-50	B35U	CEC COC	Grains, distillery	30	E35	CEC
Aluminum Chips	7-15	E46V	COC	Grass seed	10-12	B25NY	COC
Aluminum Oxide	60-120	A17M	COC	Gravel, under 1"	90-100	D36	CEC COC
Ashes, coal	35-40	C46T	CEC	Gypsum, calcined	55-60	C36	CEC COC
Asphalt, crushed	45	C35	CEC COC	Gypsum, Raw 1"	70-100	D36	CEC COC
Bakelite, Pow'd	30-45	B25	COC	Gypsum, powdered	60-80	A46	CEC COC
Baking Powder	40-55	A35	COC	Hops, dry spent	35	E45	CEC
Barley, whole	36-48	B25H	CEB	Hops, wet spent	50-55	E45T	CEC
Bauxite, crushed	75-85	D37	CEC COC	Ice, crushed	35-45	D15	CEC COC
Beans, castor	36	C25W	CEC COC	Lime, ground	60-65	B45X	CEC COC
Beans, Navy, dry	48	C25	CEC COC	Lime, hydrated	40	B36MX	COC
Bones, crushed	35-50	D46	CEC COC	Lime, pebble	53-56	D45	CEC COC
Bones, grd. minus 1/8	50	B36	CEC COC	Limestone, Agric.	68	B36	CEC COC
Boneblack	20-25	A25Y	COC	Limestone, crushed	85-90	D36	COC
Bonemeal	50-60	B36	CEC	Maize	40-45	B15N	CEB
Borax, powdered	45-55	B26T	CEC	Malt, dry, ground	20-30	B35N	CEC
Bran	16-20	B35NY	CEC	Malt, whole	20-30	B35N	CEC
Brewers grain spent, dry	14-30	C35	CEC	Malt, Meal	36-40	B25	CEC
Brewers grain spent, wet	55-60	C45T	CEC	Marble, crushed	80-95	C37	COC
Buckwheat	37-42	B25N	CEB	Milk, malted	27-30	A45PX	CEC
Cast iron boring	130-200	C46	CEC COC	Muriate of potash	70	B37	CEC COC
Cement, bulk	75-95	A26M	CEC COC	Oats	26	C25N	CEB
Cement, clinker	75-95	D37	CEC COC	Oats, rolled	19-24	C35NY	CEC
Chalk, crushed	75-95	D26	CEC COC	Oxalic acid crystal	60	B45U	CEB
Chalk, pulverized	67-75	A26MX	COC	Phosphate, acid, Fert.	60	B25T	CEC
Charcoal	18-28	D46Q	COC	Phosphate, Brk.	75-85	D36	CEC COC
Clay, Brick, Dry, Fire	100-120	C37	CEB	Phosphate rock, Pulv.	60	B36	CEC COC
Coal, Anth.	55-61	D35TY	CEC COC	Phosphate sand	90-100	B37	CEB COC
Coal, Bitum. Miner.	40-60	C35LNXY	CEC	Pumice, ground	42-48	B47	COC
Coal, Bitum. sized	45-50	C35QV	CEC	Rice, hulled	45-49	B25	CEB
Coffee, grn. bean	25-32	C35Q	CEC COC	Rice, rough	32-36	B35N	CEB
Coffee, roasted	20-30	B45DQU	CEC COC	Rice, bran	20	B35NY	CEC
Coke, loose	23-35	D47QVT	CEB	Rice, grits	42-45	B35	CEC
Coke, petroleum	35-45	D37Y	CEB	Rubber, ground	23-50	C45	CEC COC
Coke, breeze	25-35	C47Y	CEB	Rye	42-48	B15N	CEB
Copra, lumpy	22	D35	CEC COC	Salt, fine	70-80	B36TU	CEC COC
Copra, cake lumpy	25-30	D35	CEC COC	Salt, Coarse	45-60	C36TU	CEC COC
Copra cake, grd.	40-45	B35W	CEC COC	Salt, cake, coarse	85	B36TU	CEC COC
Copra meal	40-45	B26	CEC COC	Sand, damp bank	110-130	B47	CEB
Cork, fine or gran.	5-15	B45MY	COC	Sand, dry bank	90-110	B37	CEB
Corn, cracked	40-50	C35W	CEC	Sand, foundry	90-100	D37Z	CEB
Corn, shelled	45	C25	CEB	Shale, crushed	85-90	C36	CEB
Corn germs	21	B35W	CEC	Slag, Furnace	60-65	C37	COC
Corn grits	40-45	B35	CEC	Slate, crushed	80-90	C36	CEB COC
Corn Sugar	30-35	B35	CEC	Soda ash, light	20-35	A36Y	COC
Cornmeal	32-40	B35W	CEC	Soda ash, heavy	55-65	B36	CEC COC
Cottonseed de-linted	22-40	C35W	CEB	Soybeans, cracked	30-40	C36NW	CEC
Cottonseed, w/lint	18-25	C45W	CEB	Soybeans, whole	45-50	C26NW	CEB
Cottonseed, cake lumpy	40-45	D35W	CEC	Soybean cake over 1/2"	40-43	D35W	CEC
Cottonseed hulls	12	B45Y	COC	Soybean flakes, raw	18-26	C35Y	CEC
Cottonseed meal ext.	35-40	B45Y	CEC	Soybean flour	27-30	A35MN	CEB
Cottonseed meats dry	40	B35W	CEC	Soybean meal	40	B35	CEC
Dolomite, crushed	80-100	C36	CEC COC	Steel chips, cracked	100-150	D47WXZ	COC
Feldspar, Grd.	65-80	B36	CEC COC	Sugar beet, pulp, dry	12-15	C26	COC
Feldspar, Pwd.	100	A46	COC	Sugar beet, pulp, wet	25-45	C35X	COC
Flaxseed	43-45	B25NW	CEB	Sugar, raw	55-65	B35PX	CEC
Flaxseed cake	48-50	D35W	CEC	Tanbark, Ground	55	B45	CEC
Flaxseed meal	25-45	B35W	CEC COC	Timothy Seed	36	B35NY	COC
Flour, wheat	33-40	A45PN	CEB	Wheat	45-48	C25N	CEB
				Wheat, cracked	40-45	B25N	CEC
				Wheat germ	18-28	B25	CEC
				Wood Chips	10-30	E45VY	CEB

CEB—Centrifugal, Belt
 CEC—Centrifugal, Chain
 COB—Continuous, Belt
 COC—Continuous, Chain

POLYMER AND NYLON ELEVATOR BUCKETS... THE TOUGHEST CONDITIONS

SPECIALLY DESIGNED FOR FEED GRAINS, FERTILIZER, SAND, SALT, SUGAR, CORROSIVE CHEMICALS, PLASTICS, ANIMAL BY-PRODUCTS



Scientifically Correct Contour for highest production

- SCC Industries' polymer elevator bucket is engineered with the correct shape for efficient handling of a wide variety of materials.
- The relationship of the face angle, lip to back depth and smooth molded corner radius is the secret of the SCC bucket's high volume efficiency. The design has been proven in the field to discharge effectively over a wide variation of pulley sizes and diameters.
- The standard SCC Polymer bucket is FDA approved material and yellow color. White and other colors are available on special order. Buckets are stocked in 15 sizes pre-drilled or solid for drilling to customer specification.
- Recommended mounting is with SCC Norway bolts with flat steel washer on the inside of the bucket under the nut and lock washer. Norway bolts are stocked at all of the SCC Industries plants.

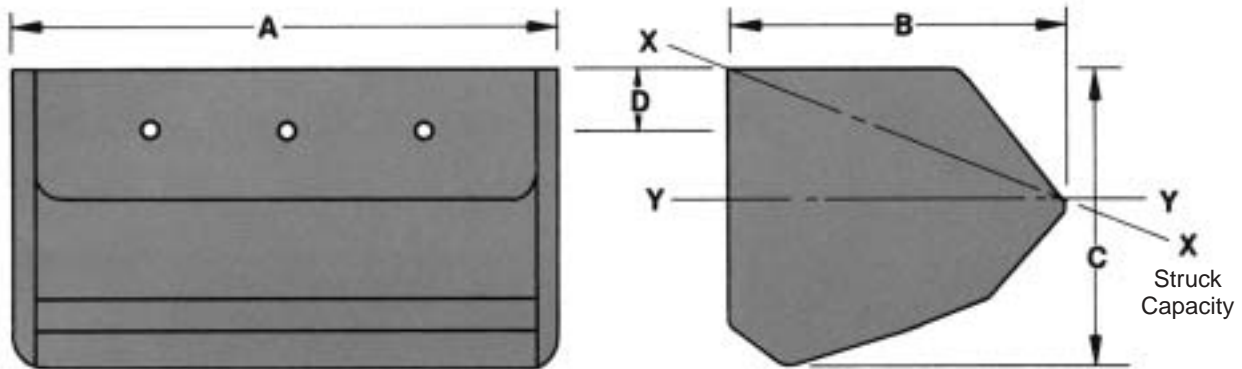

Nominal Size	Part Number	Average Weight	DIMENSIONS				STANDARD DRILLING			Cubic Inch Capacity		Minimum Spacing on Belt
			A	B	C	D	No. of Holes*	Hole Centers	Bolt Diameter	y--y	x--x	
6x4	408-0156	.53	6 ³ / ₈	4 ³ / ₈	4 ¹ / ₈	1 ³ / ₈	2	4 ³ / ₈	1/4	46	60	6"
7x4	408-0206	.61	7 ³ / ₈	4 ³ / ₈	4 ¹ / ₈	1 ³ / ₈	3	2 ¹¹ / ₁₆	1/4	51	71	6"
7x5	408-0222	1.0	7 ¹ / ₈	5 ¹ / ₂	5 ¹ / ₈	1 ¹ / ₂	3	2 ¹¹ / ₁₆	1/4	74	108	7"
8x5	408-0339	1.15	8 ¹ / ₂	5 ¹ / ₂	5 ¹ / ₈	1 ¹ / ₂	3	3 ³ / ₁₆	1/4	91	124	7"
9x5	408-0446	1.26	9 ¹ / ₂	5 ¹ / ₂	5 ¹ / ₈	1 ¹ / ₂	3	3 ⁵ / ₈	1/4	103	137	7"
9x6	408-0552	1.61	9 ¹ / ₂	6 ¹ / ₂	6 ¹ / ₈	1 ³ / ₄	3	3 ⁵ / ₈	1/4	156	207	8"
10x6	408-0669	1.75	10 ¹ / ₂	6 ¹ / ₂	6 ¹ / ₈	1 ³ / ₄	3	4 ¹ / ₈	1/4	168	224	8"
11x6	408-0776	1.80	11 ¹ / ₂	6 ¹ / ₂	6 ¹ / ₈	1 ³ / ₄	4	3	1/4	185	248	8"
12x6	408-0818	1.88	12 ¹ / ₂	6 ¹ / ₂	6 ¹ / ₈	1 ³ / ₄	4	3 ³ / ₈	1/4	200	278	8"
11x7	408-0883	2.25	11 ¹ / ₂	7 ⁵ / ₈	7 ¹ / ₈	2	4	3	5/16	232	343	9"
12x7	408-0990	2.35	12 ¹ / ₂	7 ⁵ / ₈	7 ¹ / ₈	2	4	3 ³ / ₈	5/16	255	383	9"
14x7	408-1105	2.75	14 ⁵ / ₈	7 ⁵ / ₈	7 ¹ / ₈	2	5	3	5/16	306	437	9"
16x7	408-1212	3.13	16 ⁵ / ₈	7 ⁵ / ₈	7 ¹ / ₈	2	6	2 ⁷ / ₈	5/16	361	513	9"
16x8	408-1311	5.0	16 ⁵ / ₈	8 ³ / ₄	8 ¹ / ₈	2 ¹ / ₄	6	2 ⁷ / ₈	5/16	516	734	10"
18x8	408-1410	5.5	18 ⁵ / ₈	8 ³ / ₄	8 ¹ / ₈	2 ¹ / ₄	6	3 ¹ / ₈	5/16	576	814	10"

* A flat steel washer is required under the nut and lock washer inside the bucket.
Part numbers above are for standard punched buckets. Contact your nearest SCC Industries Representative for order information and pricing for blank or special punched buckets.

High Density Polyethylene for wear resistance, low maintenance

- The material used in the SCC bucket is among the toughest and most chemically inert of the space age polymers. It has a naturally slippery surface which promotes the discharge of even sticky materials.
- Its resilient surface resists damage and wear with even the most abrasive of materials such as sand or stone products. It is naturally corrosion resistant for no-rust performance with even the most difficult materials. It will remain flexible in ambient temperatures from minus 50°F to 220°F.
- The SCC polymer bucket is injection molded in one piece with smooth rounded corners and no seams to trap or clog with material. When elevating material that tends to pack or freeze such as fertilizer or wet sand, we recommend that a Nu-Hy bucket replace every tenth bucket on the belt. Nu-Hy buckets are stocked at all of the SCC Industries plants.

Style "AA" Nylon



Screw Conveyor Style "AA" Nylon Buckets are ideal for use on fertilizer, salt, clay, foundry sand, sand, gravel and coal. Style "AA" Nylon Buckets should not be used on large dense materials like stone and ores. Sharp edged materials and materials over 275 degrees F° should be avoided.

Part No.*	Size (inches)	Capacity** Cu. Ft.	Weight (lbs)
408-1675	6 x 4	.022	.7
408-1691	8 x 5	.044	1.4
408-1717	10 x 6	.085	2.1
408-1733	12 x 7	.121	3.6
408-1758	14 x 7	.145	4.0
408-1774	16 x 7	.169	4.4
408-1790	16 x 8	.228	5.9
408-1816	18 x 8	.331	6.3

* Part Number shown is for non-punched bucket – punching style must be specified on order.

** Based on water level.

STYLE "AA" MALLEABLE IRON BUCKETS BUILT RUGGED FOR HEAVY DUTY ABRASIVE APPLICATIONS



SCC Industries has a line of Style "AA" high quality Malleable Iron Buckets for centrifugal service, belt or chain. These buckets are designed to provide longer life – which means less downtime for your bulk material handling operation. They are replacement items for SCC Industries Industrial Grade Bucket elevators as well as other makes. So for high quality, broad design, configuration and material selection from carbon steel, polymer, stainless steel, malleable iron or nylon, SCC Industries Elevator Buckets are one up on the competition. Contact us for more information on our line of Elevator Buckets.

Part No.*	Size (inches)	Capacity** Cu. Ft.	Weight (lbs)
408-1501	6 x 4	.022	3.2
408-1535	8 x 5	.046	6.8
408-1550	10 x 6	.086	10.3
408-1576	12 x 7	.139	16.5
408-1592	14 x 7	.167	18.5
408-1618	16 x 8	.251	26.3

* Part number shown is for non-punched bucket – punching style must be specified on order.

** Based on water level.

HAMMOND CONTINUOUS STEEL ELEVATOR BUCKETS

Continuous Steel Elevator Buckets are available in low front, medium front and high front types. All types are fabricated with extended sides which function as a chute for the discharge of each succeeding bucket. This provides for a clean discharge at slow speed operation. Continuous Buckets are primarily used for the elevating of materials of a bulky or gritty nature, such as crushed stone, coal, ore, etc.

The application of high, medium or low front buckets is determined by the material elevated and the incline of the elevator. These buckets are formed with a flat surface at bottom to prevent accumulation of materials.



Continuous Steel Elevator Bucket, High Front (Welded Construction)



Continuous Steel Elevator Bucket, Low Front (Welded Construction)



Continuous Steel Elevator Bucket, Medium Front (Welded Construction)

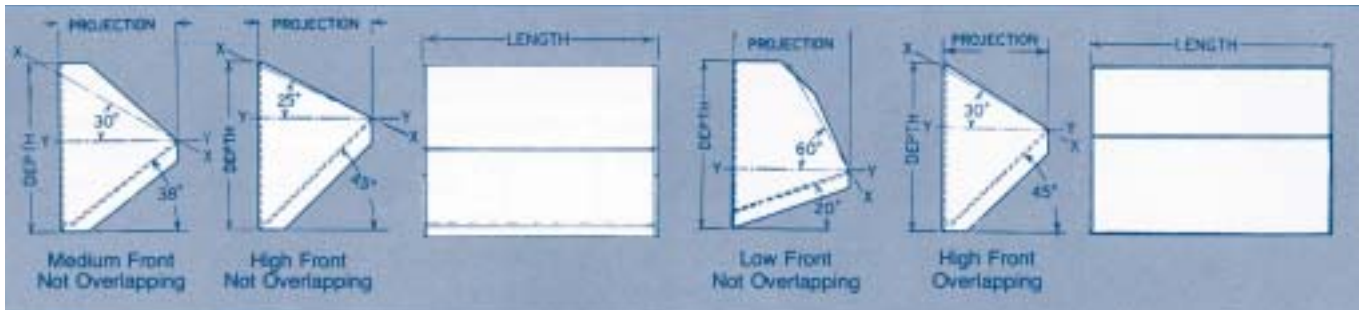

MEDIUM FRONT, NOT OVERLAPPING FOR VERTICAL ELEVATORS AND ELEVATORS INCLINED UP TO 15 DEGREES HANDLING FREE-FLOWING MATERIAL								
BUCKET SIZE INCHES			WEIGHT EACH LBS.				CAPACITY IN CUBIC FEET*	
Length	Proj.	Depth	12 Ga.	10 Ga.	3/16"	1/4"	Filled to Line x-x	Filled to Line y-y
8	5	7 3/4	5.1	6.3	8.7		.080	.048
9	6	9 1/4	6.7	8.6	11.9		.116	.066
10	5	7 3/4	5.9	7.4	10.2		.100	.060
10	6	9 1/4	7.2	9.2	12.7		.129	.074
10	7	11 5/8	9.3	11.9	16.5		.192	.115
10	8	11 5/8	9.9	12.8	17.8		.235	.135
11	6	9 1/4	7.7	9.9	13.6		.142	.081
12	6	9 1/4	8.5	10.5	14.5		.155	.091
12	7	11 5/8	10.4	13.4	18.6		.230	.124
12	8	11 5/8	11.2	14.4	20.0		.275	.172
14	7	11 5/8	11.6	14.9	20.7		.270	.159
14	8	11 5/8	12.4	16.0	22.2	29.1	.323	.201
16	8	11 5/8	13.7	17.6	24.5	32.0	.370	.230
16	12	17 5/8		29.9	40.6	54.8	.833	.462
18	8	11 5/8	14.9	19.2	26.7	35.0	.415	.262
18	10	15		25.9	36.1	47.3	.690	.402
20	8	11 5/8	16.1	20.8	29.0	38.0	.458	.295
20	12	17 5/8		34.8	48.5	63.9	1.047	.581
24	10	11 5/8		27.4	38.2	50.0	.725	.374
24	12	17 5/8		39.8	55.4	73.1	1.255	.695

HIGH FRONT, NOT OVERLAPPING FOR VERTICAL ELEVATORS HANDLING SLUGGISH MATERIAL								
BUCKET SIZE INCHES			WEIGHT EACH LBS.				CAPACITY IN CUBIC FEET*	
Length	Proj.	Depth	12 Ga.	10 Ga.	3/16"	1/4"	Filled to Line x-x	Filled to Line y-y
8	5	7 3/4	4.9	6.2	8.5		.083	.052
10	5	7 3/4	5.7	7.3	10.0		.104	.065
10	6	9 1/4	7.2	9.1	12.6		.151	.098
10	7	11 5/8	9.1	11.6	16.0		.207	.130
12	6	9 1/4	8.3	10.4	14.4		.180	.116
12	7	11 5/8	10.3	13.2	18.2		.249	.157
12	8	11 5/8	11.3	14.3	20.2		.296	.207
14	7	11 5/8	11.5	14.8	20.4	26.7	.290	.184
14	8	11 5/8	12.6	16.0	22.4	28.1	.358	.242
16	8	11 5/8	13.9	17.7	24.7	32.2	.393	.278
16	12	17 5/8	30.3	41.9	55.0		.891	.637
18	10	15	26.2	36.1	47.7		.725	.495
20	12	17 5/8	35.1	49.1	64.6		1.114	.799
24	12	17 5/8	40.5	56.3	74.3		1.335	.961

LOW FRONT, NOT OVERLAPPING FOR ELEVATORS INCLINED 15 DEGREES AND OVER								
BUCKET SIZE INCHES			WEIGHT EACH LBS.				CAPACITY IN CUBIC FEET*	
Length	Proj.	Depth	12 Ga.	10 Ga.	3/16"	1/4"	Filled to Line x-x	Filled to Line y-y
10	6	9 1/4	6.8	8.8	12.1		.168	.035
10	7	11 5/8	8.5	10.8	15.1		.242	.050
12	6	9 1/4	7.8	10.0	13.8		.201	.042
12	7	11 5/8	9.6	12.3	17.1		.302	.060
12	8	11 5/8	11.2	14.4	20.1		.347	.075
14	7	11 5/8	10.7	13.7	19.1		.345	.070
16	8	11 5/8	13.6	17.4	24.3		.463	.101
16	12	17 5/8		29.3	40.7	53.6	1.093	.229
18	10	15		25.4	35.0	46.5	.940	.183
20	8	11 5/8	15.9	20.5	28.5		.573	.126
20	12	17 5/8		33.9	47.1	62.0	1.365	.287
24	12	17 5/8		38.5	53.5	70.5	1.643	.34

HIGH FRONT, OVERLAPPING USED TO REDUCE LEAKAGE IN VERTICAL ELEVATORS HANDLING FINE OR SLUGGISH MATERIAL								
BUCKET SIZE INCHES			WEIGHT EACH LBS.				CAPACITY IN CUBIC FEET*	
Length	Proj.	Depth	12 Ga.	10 Ga.	3/16"	1/4"	Filled to Line x-x	Filled to Line y-y
8	5	8 1/2	5.1	6.5	8.9		.089	.059
10	5	8 1/2	5.9	7.6	10.5		.112	.077
10	6	10	7.5	9.5	13.1		.162	.108
10	7	12 1/2	9.6	12.3	16.7		.227	.150
12	6	10	8.6	10.8	15.0		.193	.126
12	7	12 1/2	10.8	14.0	19.0		.275	.182
12	8	12 1/2	11.8	15.0	20.5	26.0	.320	.200
14	7	12 1/2	12.1	15.7	21.3		.333	.224
14	8	12 1/2	13.1	16.8	22.9	30.4	.386	.246
16	8	12 1/2	14.5	18.6	25.2	33.6	.425	.265
16	12	18 5/8		31.1	43.0	56.8	.962	.605
20	12	18 5/8		36.4	50.4	66.6	1.203	.755
24	12	18 5/8		41.7	57.8	76.4	1.444	.905

NOTE: Continuous Steel Buckets are punched to order. Provide punching requirements with your order.

*Buckets filled to line X-X or Y-Y. Actual capacity depends on style or repose of material handled and inclination of elevator.

Accessories for Ease of Operation, Long Service Life and Convenience.

- Galvanized Construction
- Stainless Steel Construction
- Heavier Gauges Available
- Curved Bottom Boots
- Top Take Up Assemblies
- External Gravity Take Ups
- Inlet and Discharge Liners:
 - Urethane
 - UHMW
 - AR – 235 steel
- Wing Type Boot Pulleys
- Slide Lagged Head Pulleys
- Non-Standard Elevator Belting:
 - Rubber belting
 - White PVC (food grade) belting
 - Hot-material belting
- Special Designs for Various Environmental Conditions
- Monitoring Devices:
 - Speed switches
 - Motion switches
 - Alignment switches
 - Bearing temperature probes
- Service Platform, Ladder, Safety Cage
- 2 and 3-Way Valve Gates
- High Speed, High Capacity Elevator Buckets Can Also Be Furnished in Perforated or Vented Design For Soft Stocks
- Diagonal Braces



SERVICE PLATFORMS

Service Platforms allow ample area for inspection lubrication and service. Decking is close-knit, non-skid heavy-gauge expanded metal grating. Substantial guard rails are 3'6" high. The platform mounts securely between or to the casing sections for maximum safety. Available as optional equipment.

SERVICE LADDERS

Service Ladders provide easy access to the platform. SCC ladders are fabricated of heavy-gauge steel and field welded to the casing section. A Safety Cage is recommended for ladders. SCC ladders are generously proportioned to permit free and easy movement of maintenance personnel. Cages can be shop welded to the ladder and become an integral part of the elevator. Ladders and cages are optional equipment.

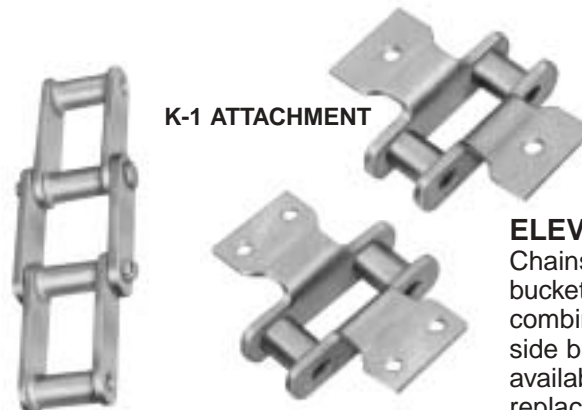
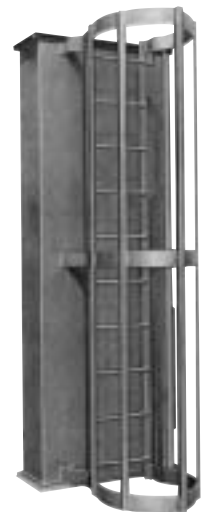

K-1 ATTACHMENT

K-2 ATTACHMENT

ELEVATOR CHAIN

Chains supplied on SCC bucket elevators are standard combination chains or steel side bar chains normally available from stock, should replacement be necessary.

Double Trunk High Capacity Bucket Elevators



The SCC Bucket Elevator has been designed and engineered to provide efficient high capacities for handling various grains, feeds, mill stock and similar free flowing granular materials. It is manufactured in many different sizes to suit individual requirements. It has double trunk legging construction with connecting angles provided on each 10 foot flange section. Vertical angle supports are included on taller units.

FEATURES

- Head pulley crowned and rubber lagged.
- Adjustable rubber throat lip.
- Quality bearings used throughout and engineered for maximum load requirements to assure smooth operation with minimum maintenance.
- Jig-welded angle flanges assure perfect alignment of legging sections. All sections are match marked for simple field erection.
- SCOR – PVC belt is jig-punched for quick and accurate mounting of buckets.
- Inlet hopper feeds buckets uniformly whether on up or down leg.
- Weather-tight inspection door included on first 10 ft. section of leg casing.
- Dust-tight heavy-duty take-ups.
- Boot pulley of rugged crown-faced design.
- Large slanted clean-out slides in boot.
- #10GA or 3/16" thick boot sections.
- #12 or 10GA head sections.
- Intermediate casing construction Std. is 12GA.

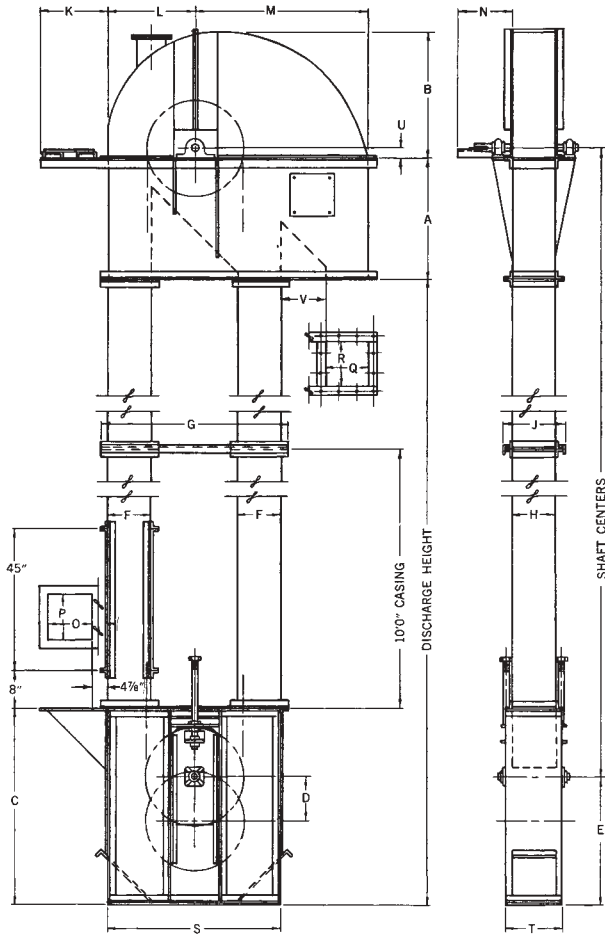

SPECIFICATIONS

Elevator Catalog Number	Capacity Bu/Hr		Speed F.P.M.		Pulley R.P.M.		Bucket Size
	Low Speed	High Speed	Low Speed	High Speed	Low Speed	High Speed	
5420	640	890	283	393	54	75	5" x 4"
7524	1360	1870	314	433	50	69	7" x 5"
9524	1840	2540	314	433	50	69	9" x 5"
9530	2280	3200	392	550	50	70	9" x 5"
11630	3325	4515	353	479	45	61	11" x 6"
12736	4380	6000	386	528	41	56	12" x 7"
14736	5170	7070	386	528	41	56	14" x 7"
16736	5864	8295	386	546	41	58	16" x 7"
16842	8841	12,447	429	604	39	55	16" x 8"
18842	9774	13,762	429	604	39	55	18" x 8"
18848	10,595	14,901	465	654	37	52	18" x 8"
DOUBLE ROW* 16842-D	17,682	24,894	429	604	39	55	16" x 8"
DOUBLE ROW* 18842-D	19,549	27,523	429	604	39	55	18" x 8"
DOUBLE ROW* 18848-D	21,189	29,801	465	654	37	52	18" x 8"
DOUBLE ROW* 18860-D	23,604	33,624	518	738	33	47	18" x 8"

*These units will have a double row of buckets to enhance capacity.

DIMENSIONS

Dimensions In Inches																	
Elevator Catalog No.	A	B	C	D	E	F	H	L	M	O	P	Q	R	S	T	U	V
5420	25	26 ¹ / ₂	42 ¹ / ₈	9	25 ¹⁵ / ₁₆	9	8	18 ¹ / ₁₆	36 ¹ / ₁₆	8	7 ⁷ / ₈	9	8	35 ⁷ / ₈	11 ¹ / ₈	2 ³ / ₈	9
7524	30	31 ¹ / ₄	45 ³ / ₈	9	29	10 ¹ / ₂	10	21 ⁹ / ₁₆	43 ¹ / ₁₆	10	9 ⁷ / ₈	10 ¹ / ₂	10	42 ⁷ / ₈	13 ¹ / ₈	3 ¹ / ₈	11
9524	30	31 ¹ / ₄	45 ⁵ / ₈	9	29	10 ¹ / ₂	13	21 ⁹ / ₁₆	43 ¹ / ₁₆	10	12 ⁷ / ₈	10 ¹ / ₂	13	42 ⁷ / ₈	16 ¹ / ₈	3 ¹ / ₈	11
9530	37	34 ³ / ₈	48 ¹ / ₈	9	32	10 ¹ / ₂	13	24 ⁹ / ₁₆	50 ⁵ / ₁₆	11	12 ⁷ / ₈	10 ¹ / ₂	13	48 ⁷ / ₈	16 ¹ / ₈	3 ¹ / ₈	15 ¹ / ₄
11630	37	36 ³ / ₄	60 ¹ / ₈	12	36 ¹ / ₂	12	15	26 ¹ / ₁₆	50 ¹³ / ₁₆	14	14 ⁷ / ₈	12	15	51 ⁷ / ₈	18 ¹ / ₈	3 ³ / ₄	12 ³ / ₄
12736	44	41 ⁷ / ₈	60 ¹ / ₈	12	40	13 ¹ / ₂	16	30 ⁹ / ₁₆	58 ¹³ / ₁₆	15	15 ⁷ / ₈	13 ¹ / ₂	16	60 ⁷ / ₈	19 ¹ / ₈	4	14 ³ / ₄
14736	44	41 ⁷ / ₈	60 ¹ / ₈	12	40	13 ¹ / ₂	19	30 ⁹ / ₁₆	58 ¹³ / ₁₆	15	18 ⁷ / ₈	13 ¹ / ₂	19	60 ⁷ / ₈	22 ¹ / ₈	4	14 ³ / ₄
16736	44	41 ⁷ / ₈	60 ¹ / ₈	12	40	13 ¹ / ₂	21	30 ⁹ / ₁₆	58 ¹³ / ₁₆	15	20 ⁷ / ₈	13 ¹ / ₂	21	60 ⁷ / ₈	24 ¹ / ₈	4	14 ³ / ₄
16842	51	46	72 ⁷ / ₈	12	44	14 ¹ / ₂	21	34 ⁹ / ₁₆	64 ⁹ / ₁₆	18	20 ⁷ / ₈	14 ¹ / ₂	21	68 ⁷ / ₈	25 ¹ / ₈	4 ¹ / ₂	15 ¹ / ₂
18842	51	46	72 ⁷ / ₈	12	44	14 ¹ / ₂	23	34 ⁹ / ₁₆	64 ⁹ / ₁₆	18	22 ⁷ / ₈	14 ¹ / ₂	23	68 ⁷ / ₈	2 ¹ / ₈	4 ¹ / ₂	15 ¹ / ₂
18848	59	50	84	12	47	14 ¹ / ₂	23	37 ⁹ / ₁₆	68 ¹³ / ₁₆	18	22 ⁷ / ₈	16	23	74 ⁷ / ₈	27 ¹ / ₈	4 ¹⁵ / ₁₆	21
DOUBLE ROW* 16842-D	51	46	84	12	51	14 ¹ / ₂	38	34 ⁹ / ₁₆	64 ⁹ / ₁₆	18	32 ⁷ / ₈	14 ¹ / ₂	38	68 ⁷ / ₈	42 ¹ / ₈	4 ¹⁵ / ₁₆	15 ¹ / ₂
DOUBLE ROW* 18842-D	51	46	84	12	51	14 ¹ / ₂	42	34 ⁹ / ₁₆	64 ⁹ / ₁₆	18	41 ⁷ / ₈	14 ¹ / ₂	42	68 ⁷ / ₈	46 ¹ / ₈	4 ¹⁵ / ₁₆	15 ¹ / ₂
DOUBLE ROW* 18848-D	59	50	84	12	53	14 ¹ / ₂	42	37 ⁹ / ₁₆	68 ¹³ / ₁₆	18	41 ⁷ / ₈	16	42	74 ⁷ / ₈	46 ¹ / ₈	4 ¹⁵ / ₁₆	15 ¹ / ₄
DOUBLE ROW* 18860-D	67	60	96	12	60	14 ¹ / ₂	42	42 ⁹ / ₁₆	81 ¹³ / ₁₆	18	41 ⁷ / ₈	18	42	84 ⁷ / ₈	46 ¹ / ₈	4 ¹⁵ / ₁₆	21

EXPERIENCE IN MOTION

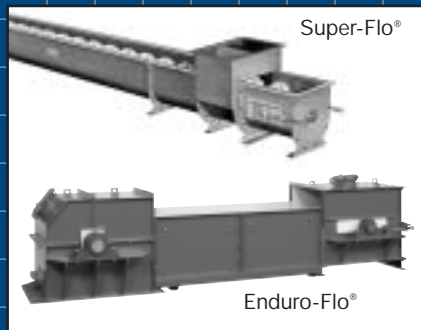
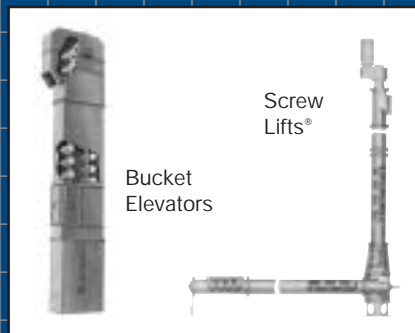

**For Over 70 Years We Have Been A Dependable Source For
Performance Proven Industrial Bulk Material Handling Equipment.
Put Our Experience to Work for You.**



**THE EXPERIENCE
TO HANDLE IT RIGHT!®**

Screw Conveyor Corporation®

HUNTSMAN, INC
Packaging, Processing and Dust Control

2362 Warren Ave.
Twin Falls, ID 83301
mail@huntsmancorp.com

Ph. (208) 733-2214
Toll Free: (888) 812-3377
Fax: (208) 733-2240